

# How to be a Successful Renter

Your guide to understanding all  
there is to know about renting.

**BEGIN**



# How to be a successful Renter!

This educational curriculum has been prepared by the Virginia Housing, with great appreciation to the U.S. Department of Housing and Urban Development (HUD), Virginia Fair Housing Office of Richmond, Virginia Department of Housing and Community Development (DHCD), Legal Aid Society of Eastern Virginia, and the many industry partners throughout the Commonwealth that provided valuable feedback.

This guide is provided solely as an educational resource and does not provide legal opinion. Virginia Housing is a self-supporting, not-for-profit organization created by the Commonwealth of Virginia in 1972, to help Virginians attain quality, affordable housing. Virginia Housing provides mortgages, primarily for first-time homebuyers and developers of quality rental housing. We use no state taxpayer dollars, but raise money in the capital markets to fund our loans. We also teach free homeownership classes, and help people with disabilities and the elderly make their homes more livable. Virginia Housing works with lenders, developers, local governments, community service organizations and others to help put quality housing within the reach of every Virginian.



# Menu

- 6 Welcome - How to be a Successful Renter**
- 7 Steps to Renting**
- 9 Chapter 1 - Are You Financially Ready to Rent?**
  - 10 Advantages and Challenges of Renting
  - 11 Why Create a Spending and Savings Plan?
  - 12 Let's Get Started!
  - 13 Why Develop a Savings Strategy?
  - 14 Savings Scenario
  - 15 Using Credit Wisely
  - 15 Beware of Junk Mail
  - 16 Managing and Reducing Debt
  - 18 You Are On Your Way
- 19 Chapter 2 - The Ins & Outs of Credit**
  - 20 How Landlords Use Credit History
  - 20 Issuers of Credit
  - 21 Credit Reporting Agencies: Understanding the Big Three
  - 22 Free Annual Credit Reports: What's In It for You?
  - 23 How to Request Your Credit Report
  - 23 Reading a Credit Report
  - 29 Disputing Incorrect Credit Report Information
  - 31 Unwanted Phone Calls and Junk Mail
  - 31 Managing and Reducing Debt
  - 32 How is the Credit Score Determined?
  - 33 How to Get Your Credit Score
  - 33 Establishing Credit
- 34 Ways to Improve Your Credit Score
- 35 Working With Housing, Credit and Financial Counselors
- 36 Avoiding Identity Theft
- 37 What to Do if You Become a Victim of Identity Theft
- 38 Chapter 3 - How to Find the Right Place**
  - 39 Fair Housing Laws
  - 41 Needs vs. Wants
  - 44 Rental Search Assistance
  - 46 Types of Rental Properties
  - 49 Homeowner Association/Condominium Renting
  - 50 Special Military Provisions
  - 50 People with Disabilities
  - 51 Renting Alternatives
  - 51 Beware of Rental Scams
- 53 Chapter 4 - Handling the Application Process**
  - 54 Private Owner vs. Property Management Company
  - 56 Landlord's Objective: What Are They Looking For?
  - 56 Obtaining the Application
  - 57 Completing the Application
  - 59 Signing the Application and Other Related Documents
  - 60 Submitting the Application
  - 60 The Application Fee
  - 60 The Verification Process
  - 61 Reasons for Application Denial
  - 62 Submitting the Security Deposit

[Menu Continued on Next Page](#) ►

# Menu

## **63 Chapter 5 - Understanding the Lease Agreement**

- 64 What is the Lease Agreement?
- 64 VRLTA Landlords and Opt-Out Landlords
- 65 Before You Sign
- 66 Verbal Lease Agreements
- 67 Month-to-Month Lease
- 67 Standard Terms of the Lease Agreement
- 73 Optional Lease Provision
- 74 Addendum to Lease
- 75 Types of Rental Agreements
- 76 As-is Lease Agreement
- 76 Common Misunderstandings
- 78 Rent-to-Purchase Programs
- 81 Questions to Ask Before You Sign
- 82 Tips to Keep in Mind

## **83 Chapter 6 - Getting Back Your Security Deposit**

- 84 What is a Security Deposit?
- 84 What Can the Deposit Cover?
- 86 Maximum Amount by Law
- 86 Other Possible Upfront Costs
- 87 Tiered-based Security Deposits
- 88 Before You Move In
- 88 Walk-through Inspection
- 89 Security Deposit Refund
- 90 Forwarding Address
- 90 Disputing the Deductions
- 90 Seek Assistance

- 90 Clean Up and Damages

## **92 Chapter 7- Life as a Renter: Rights & Responsibilities**

- 93 Virginia Residential Landlord and Tenant Act (VRLTA)
- 94 Confidentiality
- 94 Notices
- 95 Disclosures
- 96 Right of Entry
- 97 Decent, Safe and Sanitary Rental
- 98 Disabled Tenant or Household Member
- 99 Utilizing the Premises
- 100 Rent
- 101 Advance or Prepaid Rent
- 101 Rent Increase
- 101 Locks and Peepholes
- 102 Keys
- 102 Smoke and Carbon Monoxide Detectors
- 102 Extermination
- 103 Painting and Alterations

## **104 Chapter 8 - Housekeeping, Maintenance & Repairs**

- 105 Building and Housing Codes
- 105 Landlord's Responsibilities
- 106 Tenant's Responsibilities:
- 111 Landlord Negligence
- 112 Emergencies
- 113 Preventive Maintenance
- 115 Pest Exterminations

[Menu Continued on Next Page](#) ►

# Menu

- 116 Bedbugs
- 117 Mold
- 118 Renters Insurance
- 119 Chapter 9 - The Right Way to Terminate the Lease**
- 120 Provide the Landlord with Notice
- 120 Tenant's Intent to Vacate: Provide Sufficient Notice
- 121 Tenant Termination: Before the Lease Expires
- 123 Tenant Termination: Landlord Noncompliance
- 125 Landlord Termination: Lease Expiration
- 125 Landlord Termination: Transfer of Ownership, Property Sale or Foreclosure
- 126 Landlord Termination: Noncompliance
- 130 "Accept with Reservation"
- 131 Right of Redemption
- 132 Warrant in Debt
- 133 Time Line at a Glance
- 134 Resources for Renters**
- 134 Fair Housing Consultation
- 135 Federal Acts and Legislation
- 136 Counseling
- 137 Legal
- 137 Virginia Courts
- 138 Financial Assistance
- 139 Rental Search
- 140 Reducing Solicitations

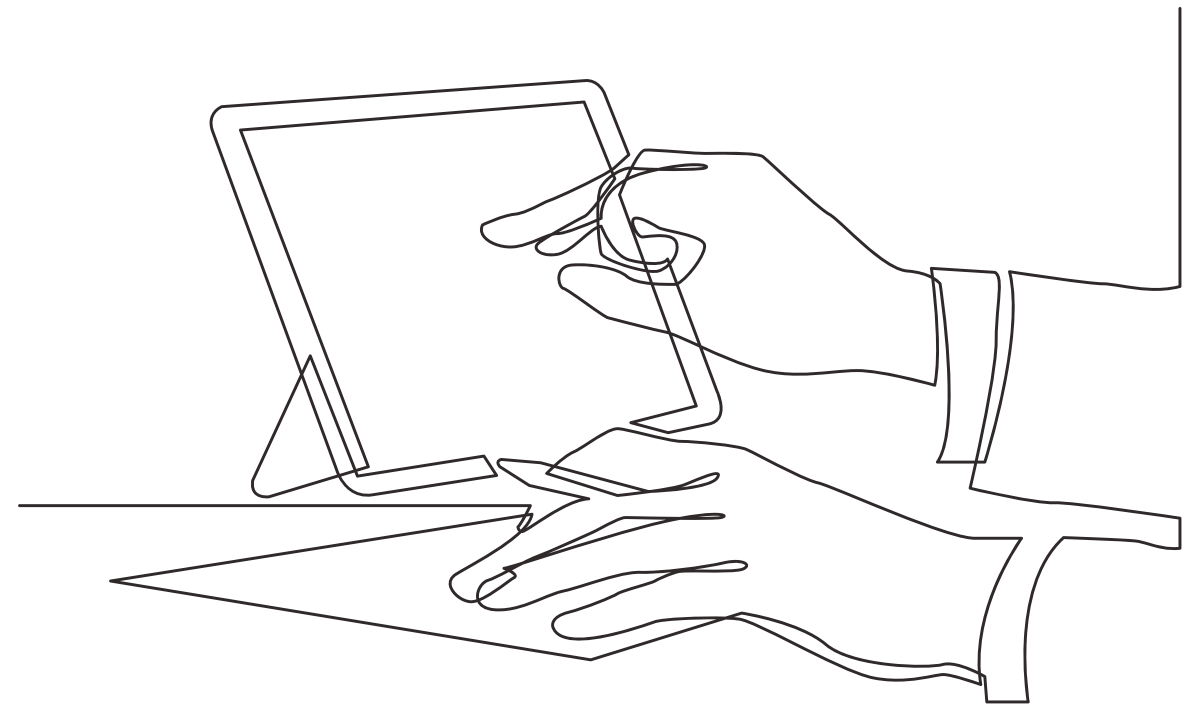

# Welcome

## How to be a Successful Renter

Whether it's a house, apartment, duplex or townhouse, renting versus purchasing can have its advantages. In this chapter, you'll learn the pros and cons of renting. You'll also learn how to create a personal Savings and Spending Plan, ways to manage your debt and how to find additional community resources that can help you be a knowledgeable renter.



## Menu

- 1 Are You Financially Ready to Rent?
- 2 The Ins & Outs of Credit
- 3 How to Find the Right Place
- 4 Handling the Application Process
- 5 Understanding the Lease Agreement
- 6 Getting Back Your Security Deposit
- 7 Life as a Renter: Rights & Responsibilities
- 8 Housekeeping, Maintenance & Repairs
- 9 The Right Way to Terminate the Lease

# Steps to Renting

- 1. Congratulations, you've taken the first step!** Keep reading "How to be a Successful Renter."
- 2. Decide if you're financially ready.** Before you begin the rental search, know what you can afford. Creating a personal Spending and Savings Plan, which identifies your total income, expenses and debt, is a big part of ensuring your rental success. How much can you comfortably afford to spend on rent and other related costs?
- 3. Identify your needs and wants.** Make a list of must-haves, including your price range, number of bedrooms and desired location. A list of what would be nice, but not absolutely necessary, should be considered as well. Knowing your needs and wants will help narrow the search. Browse online search engines such as Virginia Housing's comprehensive housing locator at [virginiahousingsearch.com](http://virginiahousingsearch.com)
- 4. Understand the various types of rentals and available resources.** One of the most important decisions we make is where to call home. What type of rental is right for you? The choices within your county or city may include

the traditional apartment, studio, SRO, rent assistance housing, single family home or mobile home rental. Housing counseling agencies throughout the state can assist with many aspects of renting, which include identifying other available resources. Visit [Hud.gov](http://Hud.gov) to locate a housing counselor near you.

- 5. Know the fair housing laws.** Virginia enforces fair housing laws that protect against bias. The law prohibits rental transactions that discriminate. Certain protected classes cannot be treated differently, and discriminatory treatment of them is unlawful. Once you become a tenant, additional local, state, and federal laws/acts continue to provide protection. Visit [dpor.virginia.gov/FairHousing](http://dpor.virginia.gov/FairHousing) for additional information.
- 6. Beware of scams!** Is the person you're dealing with reputable? Everyone wants a good deal, but is it really a good deal or a scam? Beware of individuals who ask for money before you have actually viewed the property and those who ask for cash only. Ask yourself, is this truly the landlord or a scam artist? Is the property actually for rent?

## Menu

- 1** Are You Financially Ready to Rent?
- 2** The Ins & Outs of Credit
- 3** How to Find the Right Place
- 4** Handling the Application Process
- 5** Understanding the Lease Agreement
- 6** Getting Back Your Security Deposit
- 7** Life as a Renter: Rights & Responsibilities
- 8** Housekeeping, Maintenance & Repairs
- 9** The Right Way to Terminate the Lease



**7. Read before you sign.**

It’s important to read and understand all documents before signing them, including the initial application, authorization forms and the lease agreement. Disclosures are equally important. Ask questions, get clarification and seek assistance from a professional if needed.

**8. Inspect the property.**

It’s highly recommended that you begin inspecting the property right away. Note any pre-existing conditions or damages in writing once you move in. Take pictures! Submit the report to the landlord for future reference, and keep a copy for your records. This report will become an invaluable document when you move out. The likelihood of the landlord charging you for pre-existing problems is minimized. And the likelihood of receiving your full security deposit refund back is maximized.

**9. Acquire renters insurance.**

“The landlord’s insurance policy will cover me if my property is damaged or destroyed in the case of an unforeseen hazard.” This is a common misunderstanding. To protect yourself against costly repairs/replacements of your personal property or liability expenses due to injury, consider

purchasing renters insurance. Policies vary, but the cost is often very affordable, to protect your furniture, clothing, electronics and household items from being a total loss. The State Corporation Commission (SCC) provides useful guides and publications for consumers at [scc.virginia.gov](http://scc.virginia.gov).

**10. Adhere to all lease provisions.**

Both the landlord and the tenant have rights and responsibilities. The landlord simply wants someone who will pay rent on time, maintain the property and follow the terms of the lease. Do this and your rental experience should be a pleasant one. But remember, the landlord is accountable as well. When the time comes, tenants can terminate the lease agreement by providing sufficient notice. However, the tenant can also seek to have the lease terminated if they believe the landlord is in noncompliance with the lease agreement. In addition, the landlord can terminate the agreement when the lease term expires and when the tenant is noncompliant. Best practice — adhere to all lease provisions. The Virginia Residential Landlord and Tenant Act (VRLTA) provides detailed information and can be found at [dhcd.virginia.gov](http://dhcd.virginia.gov).

# Menu

- 1** Are You Financially Ready to Rent?
- 2** The Ins & Outs of Credit
- 3** How to Find the Right Place
- 4** Handling the Application Process
- 5** Understanding the Lease Agreement
- 6** Getting Back Your Security Deposit
- 7** Life as a Renter: Rights & Responsibilities
- 8** Housekeeping, Maintenance & Repairs
- 9** The Right Way to Terminate the Lease





# Chapter 1

## Are You Financially Ready to Rent?

In this chapter, you'll learn the pros and cons of renting. You'll also learn how to create a personal Spending and Savings Plan, ways to manage your debt and how to find additional community resources that can help you be a knowledgeable renter.

### Menu

- 1** Are You Financially Ready to Rent?
- 2** The Ins & Outs of Credit
- 3** How to Find the Right Place
- 4** Handling the Application Process
- 5** Understanding the Lease Agreement
- 6** Getting Back Your Security Deposit
- 7** Life as a Renter: Rights & Responsibilities
- 8** Housekeeping, Maintenance & Repairs
- 9** The Right Way to Terminate the Lease

## Advantages and Challenges of Renting

There are advantages and potential challenges to renting. On the upside, renting may offer you many advantages:

- ▶ **Maintenance-free living.** In some instances, landlords may pay for utilities, such as water, sewer, trash removal and hot water. When the pipe leaks under the sink, you don't head to your nearest hardware store. Instead, you head for the phone and call your landlord.
- ▶ **Amenities.** Some rental communities provide amenities like swimming pools and fitness centers that are available to renters, often at no extra charge. Generally, rental apartments also provide appliances like refrigerators, stoves and dishwashers. This eliminates the expense of having to buy these items.
- ▶ **Lower costs.** In some cases, the cost of renting is much less than paying a mortgage. To be approved for a lease, an application fee plus a security deposit are usually required.
- ▶ **Flexibility.** Renting gives you the opportunity to more easily relocate due to career advancement, family size or other life changes. If you're new to an area, you can rent while you research neighborhoods to see where you might want to live if and when you decide to buy a home.
- ▶ **Establishing credit.** If you have bad or less-than-perfect credit, a good rental payment history can help you establish good credit, which can help you when you're ready to buy a home.

Recognizing the challenges of renting early in the process can help you avoid potential pitfalls. The challenges include:

- ▶ **Little or no privacy.** Sharing walls, floors or ceilings with neighbors can become a problem when you have to continuously listen to footsteps overhead, doors slamming and stairs being climbed along a shared wall.



**1** Are You Financially Ready to Rent?

**2** The Ins & Outs of Credit

**3** How to Find the Right Place

**4** Handling the Application Process

**5** Understanding the Lease Agreement

**6** Getting Back Your Security Deposit

**7** Life as a Renter: Rights & Responsibilities

**8** Housekeeping, Maintenance & Repairs

**9** The Right Way to Terminate the Lease

## Menu

▶	1	Are You Financially Ready to Rent?
	2	The Ins & Outs of Credit
	3	How to Find the Right Place
	4	Handling the Application Process
	5	Understanding the Lease Agreement
	6	Getting Back Your Security Deposit
	7	Life as a Renter: Rights & Responsibilities
	8	Housekeeping, Maintenance & Repairs
	9	The Right Way to Terminate the Lease

- ▶ **No financial benefit.** Tenants do not gain equity when renting the way you would as a homeowner. Renting offers no wealth creation or return on investment. The interest on mortgage payments may be tax deductible, but no portion of your monthly rent is.
- ▶ **Unstable housing cost.** There is no guarantee that a lease will be renewed when it expires. In addition, your rent can increase yearly.
- ▶ **Less freedom.** Landlords may not allow pets. They may not allow you to paint the walls or make any other changes to the property. When renting a home, you may be required to weed the garden, trim the bushes or do some other landscaping. Often, restrictions and provisions like the ones mentioned are included in the lease agreement.

## Why Create a Spending and Savings Plan?

Developing a Spending Plan that accurately reflects your current financial situation is a big part of ensuring your financial success and your ability to rent successfully. Many people avoid creating a detailed plan for their finances for a variety of reasons. Some find it stressful, others feel restricted, and many who do create one try to do it from memory. Whatever the reason, avoiding to plan now will cause you problems later.

A Spending Plan consists of two parts: income and expenses. All regular monthly income from documented sources — such as paychecks — should be included. (Irregular income such as lottery winnings or gifts is not included.)

There are three types of expenses:

- ▶ **Fixed expenses** are regular and expected, such as rent and child care.
- ▶ **Flexible expenses** are more discretionary, such as groceries, clothing and entertainment, as well as unexpected medical bills and car repairs.
- ▶ **Debt** includes credit obligations paid on a monthly basis, such as credit cards or vehicle loans.

# Let's Get Started!

1. Visit Virginia Housing's website for a Spending and Savings Plan.
2. Fill in the "Now" column on the form. In this section, you will total your expenses and subtract them from your income. You may know the exact amount you spend for utilities, insurance and other regular monthly expenses. But do you remember how much you spent last month on miscellaneous items such as fast food, vending machines or gas? Enter the amounts you remember into the form or make an educated guess.

After totaling your expenses and subtracting them from your income, did the form show you have money that you know you don't have left over each month? If so, don't worry. You're not alone. Remembering where all our money goes each month is difficult for most people, unless we keep a written record.

3. Track every penny you spend for a set period of time — one or two months — so you can see where your money is going. Even change spent in the vending machine for a soda or at the convenience store for coffee should be written down.

A small notebook that fits in your purse or pocket is a great tool for tracking your expenses. You can also download a spending tracking app on your smartphone. A business-sized envelope works great for saving receipts.

4. Now that you have a detailed picture of how you're spending your money, you've got the power to make adjustments. You may decide to:
  - ▶ Allocate a specific amount for miscellaneous spending (clothing, dining out, things you and/or your family do for fun) in your plan.
  - ▶ Reduce the amount you spend on a particular habit or activity.
  - ▶ Eliminate an expense altogether.

Whatever you do, make sure you develop a realistic Spending Plan that accurately reflects both your income and your expenses. Remember, you're creating your "road map" that will ultimately lead to an affordable rental.

## Menu



1	Are You Financially Ready to Rent?
2	The Ins & Outs of Credit
3	How to Find the Right Place
4	Handling the Application Process
5	Understanding the Lease Agreement
6	Getting Back Your Security Deposit
7	Life as a Renter: Rights & Responsibilities
8	Housekeeping, Maintenance & Repairs
9	The Right Way to Terminate the Lease

## Estimate Your “With Rent” Expenses

Now that you’ve filled in all blanks in the “Now” column on your Spending Plan, you can see what your recurring monthly expenses are. (This will help you figure out what additional expenses you may be able to handle if you decide to rent.) So, let’s begin to fill in the blanks in the “With Rent” column.

Obviously, you can only estimate what your “With Rent” expenses will be, so don’t worry if you are unsure about the numbers. Even though the exact figures may not be available, you can begin to assess some of the additional expenses you’re likely to have once you begin renting.

The purpose of beginning the “With Rent” Spending Plan is to get you thinking about some of the additional costs that you may be responsible for, such as:

- ▶ Renters insurance
- ▶ Cable/satellite TV and streaming services
- ▶ Telephone and internet service
- ▶ Utilities (electric, gas, water)
- ▶ Maintenance/repairs (if not covered by landlord)

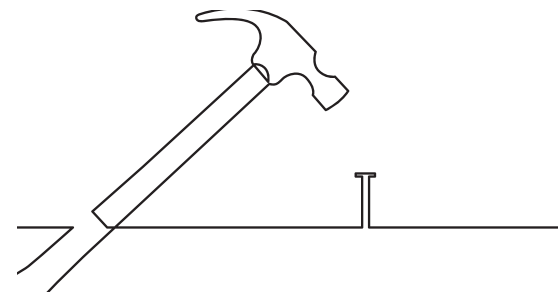

*In some cases, these expenses are paid for by the owner/landlord. It’s up to you to find out exactly what expenses you are responsible for so you’ll know what to include in your Spending and Savings Plan.*

## Why Develop a Savings Strategy?

If you experience a loss of income, such as a reduction in pay, having some cash available to pay monthly bills is extremely important. Remember, you never want to face eviction. Having money in an emergency savings account is a critical part of managing your personal finances. Developing the habit of saving takes time and persistence. Financial experts recommend you keep a separate savings account with enough funds to cover three to six months of living expenses. This money is your safety net for unforeseen expenses. Make a decision to “pay yourself first,” by committing to save a certain amount or percentage of your monthly income in your designated emergency savings account on a regular basis.

## Menu

- 1 Are You Financially Ready to Rent?
- 2 The Ins & Outs of Credit
- 3 How to Find the Right Place
- 4 Handling the Application Process
- 5 Understanding the Lease Agreement
- 6 Getting Back Your Security Deposit
- 7 Life as a Renter: Rights & Responsibilities
- 8 Housekeeping, Maintenance & Repairs
- 9 The Right Way to Terminate the Lease



Remember not to mix your “emergency” funds with other money you might be saving for goals such as a vacation, college expenses or funds needed to purchase a car or home. Make sure you have a separate account for these expenses so you don’t accidentally use the money for something other than what you originally planned to spend it on.



*If possible, consider using direct deposit through your employer, which may help reduce the temptation to stray from your plan.*

Matched Savings Programs may be available to help eligible first-time homebuyers save for a down payment, pay for college tuition or start a business by providing matching funds. Check with a HUD Housing Counseling Agency for specific program availability and eligibility requirements in your area.

## Savings Scenario

When creating a workable Spending Plan that suits your lifestyle and specific situation, it’s important to identify and understand what your comfort level is for a rental payment.



*Try this simple experiment to see if you are really comfortable with your potential rent payment: Subtract the estimated rent payment from your checking account and place it in a savings account. Try this for three months.*

**Let’s see how this works for Jon in the following scenario:**

**Example:**

Jon’s current monthly income is \$1,600. He’s been approved for an \$800 monthly rent payment. Jon would subtract \$800 from his income and place it into savings each month, leaving \$800 remaining for his living expenses.

During his three-month experiment, Jon will feel as if he’s making the \$800 rent payment, even though the \$800 is being set aside in a savings account.



# Menu



- 1 Are You Financially Ready to Rent?
- 2 The Ins & Outs of Credit
- 3 How to Find the Right Place
- 4 Handling the Application Process
- 5 Understanding the Lease Agreement
- 6 Getting Back Your Security Deposit
- 7 Life as a Renter: Rights & Responsibilities
- 8 Housekeeping, Maintenance & Repairs
- 9 The Right Way to Terminate the Lease



Conducting this experiment will give you a good idea of whether or not you would feel comfortable with a higher payment. If you find you don't miss the extra money you're putting into the savings account, and haven't had to withdraw any of it to cover expenses, then the proposed rent payment might be reasonable for you. However, if you find you need to withdraw even small amounts of the saved money for unexpected expenses, then you should consider a lower amount for a future rent payment.

## Using Credit Wisely

Making large credit purchases before being approved can be disastrous. Purchases made on credit, even those with terms such as "one year, no payments or no interest" will affect your credit score and debt-to-income ratio. It's possible to throw off your score and/or ratios enough to be denied.

It's also very important to avoid making any major purchases for the first six to 12 months after moving in to your new rental. You — and your Spending Plan — will need some time to adjust to your expenses. It's best not to make major purchases until you've become accustomed to your new expenses. It may take several months before you truly get comfortable with your new financial situation.

## Beware of Junk Mail

Watch out for the automatic loan checks and credit card offers with low interest rates you receive in the mail. Companies will tempt you with an actual check that you simply endorse and cash. By signing the check, you create a debt, which may have a very high interest rate or other unfavorable terms. It's very easy to become overextended with debt, so careful planning and caution are crucial.

Periodically, your creditors are required to send you Privacy Act notifications, along with instructions for "opting out" of having your nonpublic information shared with other businesses. Sometimes the creditor will provide a phone number you may call, or may have a form that you sign and return, directing them not to share your nonpublic information.

## Menu

- 
- 1 Are You Financially Ready to Rent?
  - 2 The Ins & Outs of Credit
  - 3 How to Find the Right Place
  - 4 Handling the Application Process
  - 5 Understanding the Lease Agreement
  - 6 Getting Back Your Security Deposit
  - 7 Life as a Renter: Rights & Responsibilities
  - 8 Housekeeping, Maintenance & Repairs
  - 9 The Right Way to Terminate the Lease



*Pay attention when throwing away what appears to be junk mail from companies you have credit accounts with. Periodically, your creditors may have a form that you sign and return directing them not to share your nonpublic information.*

## Managing and Reducing Debt

Anyone can become overextended with debt and credit. In fact, did you know that the average American adult has at least one credit card with a balance and is likely paying only the minimum required payment?

Excessive debt or credit can cause problems when applying for a lease. Although credit card interest rates vary, typically a hefty portion of a monthly payment is applied to the finance charge, leaving only a small amount to actually reduce the balance. This can become very frustrating. Because the credit card industry has become so competitive, companies will often try to lure customers with the promise of a lower interest rate.

If you have a credit card with a balance and are making your payments on time every month, call your credit card company and ask that they give you a lower rate. Rather than lose your business to another credit card company, your creditor may oblige. You may be surprised at how successful you are in doing this. Negotiating with a credit union will probably be the exception, because it may already offer a lower rate than other companies and may be unwilling to bargain.

In addition to reducing the amount of finance charge you pay each month, another way to accelerate your debt payoff is to make “Power Payments.”

**How Power Payments work:** Apply an extra amount of money monthly to one of your debts and watch how quickly the balance drops. You don’t have to apply large amounts of money to see the results; even \$5 or \$10 per month makes a big difference.

## Menu

- ▶ 1 Are You Financially Ready to Rent?
- 2 The Ins & Outs of Credit
- 3 How to Find the Right Place
- 4 Handling the Application Process
- 5 Understanding the Lease Agreement
- 6 Getting Back Your Security Deposit
- 7 Life as a Renter: Rights & Responsibilities
- 8 Housekeeping, Maintenance & Repairs
- 9 The Right Way to Terminate the Lease

**Let's see how this works for Jane in the following scenario:  
Example:**

Jane has a credit card with a \$1,000 balance, and her minimum monthly payment is \$20. If Jane makes her minimum payment each month and never uses the card again, her debt will be paid off in seven years. Jane doesn't want to make payments for that long, so she decides to apply \$10 more each month to her debt. Now Jane is making a \$30 monthly payment and her debt will be paid off in just three years! By sending just an extra \$10 per month, she will be able to pay off her debt in less than half the time.

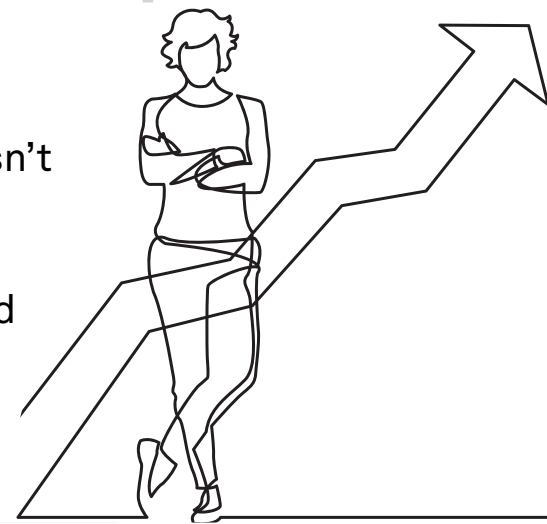

The tremendous impact of making Power Payments is even more evident when there is more than one debt to be paid off. Although it takes some discipline, you can dramatically accelerate your debt payoff if you commit to this process. After you have paid off your first debt, apply the monthly payment that you were making to the next debt, rather than spending it. In the scenario, Jane pays off her \$1,000 credit card balance and applies the \$30 payment to her next debt. By doing this with each debt, Jane will be compounding the amount of money that is applied to her debts and will pay each one off much faster.

Power Payments can also help you pay off installment debt (a debt that has a specific payment amount for a specific number of months). If your payment is paid earlier than the due date, you'll pay back less interest because the debt will be paid in full before the due date. If you increase the payment and pay a few days before the monthly payment is due, you could pay off as much as six to 12 months early.



Visit [powerpay.org](https://powerpay.org). This free resource provides tools to evaluate your debt and help you strategically use the Power Pay system on your own. The website also provides resources to help with your spending and savings plans.

## Menu

- 1 Are You Financially Ready to Rent?
- 2 The Ins & Outs of Credit
- 3 How to Find the Right Place
- 4 Handling the Application Process
- 5 Understanding the Lease Agreement
- 6 Getting Back Your Security Deposit
- 7 Life as a Renter: Rights & Responsibilities
- 8 Housekeeping, Maintenance & Repairs
- 9 The Right Way to Terminate the Lease

# You Are On Your Way

This section has taught you the importance of managing debt, negotiating with creditors and making power payments to resolve debt burden. Specifically, you learned how to:

- ▶ Create a workable Spending and Savings Plan for your household.
- ▶ Be aware of where you spend money (especially cash).
- ▶ Keep your spending to a minimum.
- ▶ Reduce your debts.

Yes, it's a lot to take on, but you can do it! Remember, there are HUD Housing and Credit Counselors in your community ready to help you work through your financial issues. A HUD Housing Counseling Agency can help you:

- ▶ Create your Spending and Savings Plan.
- ▶ Resolve credit issues.
- ▶ Prepare an action plan.



*Many organizations offer counseling at no charge. You may find their services invaluable, especially if you are preparing yourself financially for renting. Contact a HUD Housing Counseling Agency to learn more.*

The National Foundation for Credit Counseling® (NFCC®) is another resource to find certified consumer credit counselors. Visit their website at <https://nfcc.org/index.php>.

You can also find information on housing counselors on Virginia Housing's website at [VirginiaHousing.com/housingcounselors](https://VirginiaHousing.com/housingcounselors).



**Test Your Knowledge.** Take the quiz for this chapter and get a certificate of completion! You'll be asked to create a user login, if you haven't already: <https://VirginiaHousinglearningcenter.mkscloud.com>

## Menu

▶	1	Are You Financially Ready to Rent?
	2	The Ins & Outs of Credit
	3	How to Find the Right Place
	4	Handling the Application Process
	5	Understanding the Lease Agreement
	6	Getting Back Your Security Deposit
	7	Life as a Renter: Rights & Responsibilities
	8	Housekeeping, Maintenance & Repairs
	9	The Right Way to Terminate the Lease

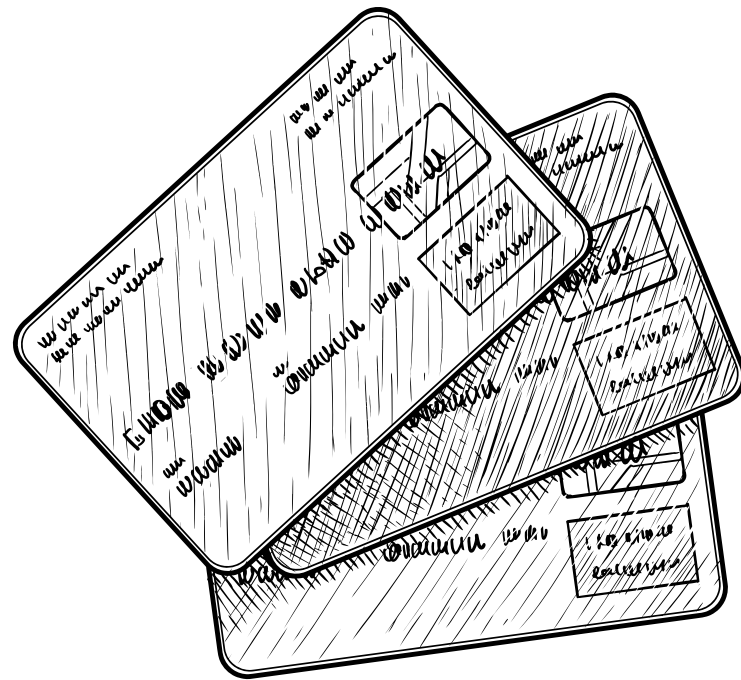

# Chapter 2

## The Ins & Outs of Credit

Good credit is important. Like it or not, credit is a significant part of our lives. If you're in the market to rent, you'll need more than sufficient income. Landlords typically run a background check on prospective tenants that includes previous rental history, criminal record and credit history.

A view of an applicant's financial history is often an indication of how likely they are to pay their rent on time. The higher a person's credit score, the lower the risk that their rent will be paid late or not at all. A credit score can make it easier, or more difficult, to get a car loan, credit card, mortgage loan, or to rent an apartment. It can also impact things like your ability to qualify for a job or the price you are charged for insurance. So it's important to use credit wisely. Making smart financial decisions to strengthen and safeguard your credit will benefit you now and in the future.

## Menu

- 1 Are You Financially Ready to Rent?
- 2 The Ins & Outs of Credit
- 3 How to Find the Right Place
- 4 Handling the Application Process
- 5 Understanding the Lease Agreement
- 6 Getting Back Your Security Deposit
- 7 Life as a Renter: Rights & Responsibilities
- 8 Housekeeping, Maintenance & Repairs
- 9 The Right Way to Terminate the Lease



# How Landlords Use Credit History

A credit history report and credit score can often demonstrate an applicant’s creditworthiness and likelihood of paying rent on time. Landlords want tenants who will consistently pay on time. Using the credit score helps to gauge a prospective tenant’s history of on-time payment of monthly obligations.

What is considered an acceptable credit history for rental purposes is completely up to each landlord. Credit scoring makes it easier for a landlord to make an objective decision based solely on credit report data. Because credit scoring doesn’t take into account race, color, national origin, religion or marital status, it removes the likelihood of personal judgment and unfair influence. Credit scoring also simplifies the credit application process by quickly delivering information that is easy to understand.

While most landlords use FICO scores to help them make decisions, each landlord makes their own decision about what the minimum acceptable score will be. There is no single “cutoff score” used by all landlords.

Since your credit is an important factor in the landlord’s decision to accept you as their renter, you might be wondering how you obtain credit. We’ll now discuss that and issuers of credit (or creditors).

## Issuers of Credit

An alternative to paying for goods and services with cash is to use credit. A plastic card issued by a financial institution or business that authorizes the holder to purchase goods or pay for services is one form of credit. Examples of major credit card issuers are American Express, MasterCard, VISA and Discover Card. Other types of credit cards include department store, other retailers and gas cards. Other forms of credit include loans (student, personal, car) and accounts opened directly with a business, such as the payment plans offered at some furniture stores.

These various issuers of credit are known as creditors. The creditor extends credit to the borrower with the agreement that the borrower will pay back the amount at a later date, generally with interest. Paying creditors as agreed upon is critical. Many creditors, but not all, will report the borrower’s payment history to agencies that collect and compile this information into a credit report. These nationwide companies are known as credit reporting agencies (or CRA).

## Menu

- 1 Are You Financially Ready to Rent?
- 2 The Ins & Outs of Credit
- 3 How to Find the Right Place
- 4 Handling the Application Process
- 5 Understanding the Lease Agreement
- 6 Getting Back Your Security Deposit
- 7 Life as a Renter: Rights & Responsibilities
- 8 Housekeeping, Maintenance & Repairs
- 9 The Right Way to Terminate the Lease



# Credit Reporting Agencies: Understanding the Big Three

Our credit history is captured in a credit report provided by the credit reporting agencies.

Anyone who has ever borrowed, or tried to borrow, money from any creditor usually has a credit history with one, if not all, of the three major credit reporting agencies. Landlords and property management companies use credit reports to qualify rental applicants.

Credit reporting agencies don't approve or deny credit, they only collect and report information. In addition, not all creditors report to any (or all) of the credit agencies, and some creditors report to only one. This typically creates three different credit reports, one with each of the three major credit-reporting agencies:

- ▶ **Equifax** covers the East Coast.
- ▶ **Experian** covers the West Coast.
- ▶ **TransUnion** covers the Midwest.

Usually, consumers have to pay to access their credit reports, but there are a few exceptions. A consumer may be entitled to a free copy of their credit report if:

- ▶ The consumer is unemployed.
- ▶ The consumer is receiving public assistance.
- ▶ The consumer has an inaccurate report because of fraud or identity theft.

If you've been denied a job, insurance or credit because of a negative credit report, you're entitled to receive a free credit report upon request within 60 days of receiving the notice of action.

It's true that you may have to pay for access to your report. However, free access is available through the major three credit reporting agencies. Next, let's find out how to receive a free credit report from all three agencies.

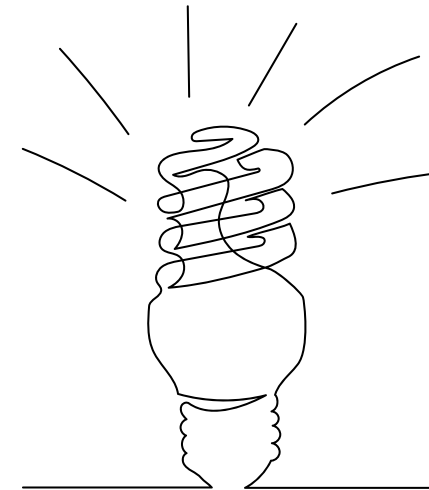

## Menu

- 1 Are You Financially Ready to Rent?
- 2 The Ins & Outs of Credit
- 3 How to Find the Right Place
- 4 Handling the Application Process
- 5 Understanding the Lease Agreement
- 6 Getting Back Your Security Deposit
- 7 Life as a Renter: Rights & Responsibilities
- 8 Housekeeping, Maintenance & Repairs
- 9 The Right Way to Terminate the Lease



*If, within 60 days of receiving the notice of action — you’ve been denied a job, insurance or credit because of a negative credit report — you’re entitled to receive a free credit report upon request.*

## Free Annual Credit Reports: What’s In It for You?

Under the Fair and Accurate Credit Transaction Act (FACT Act), you can ask to receive one free credit report every 12 months from each of the major credit reporting agencies.

You should take advantage of the FACT Act and view all three of your credit histories at least once a year to determine if the information reported is correct.

Note: Your credit score is not included in your credit report but it may be purchased.

You’ll need to decide if you want to order all three credit reports at the same time. The advantage of ordering all three at the same time is that you can easily compare them. But remember, you won’t be eligible for another free credit report for 12 months. On the other hand, spacing your requests out (for example, one credit report every four months) helps you keep track of any changes or new information that may appear on your credit report.

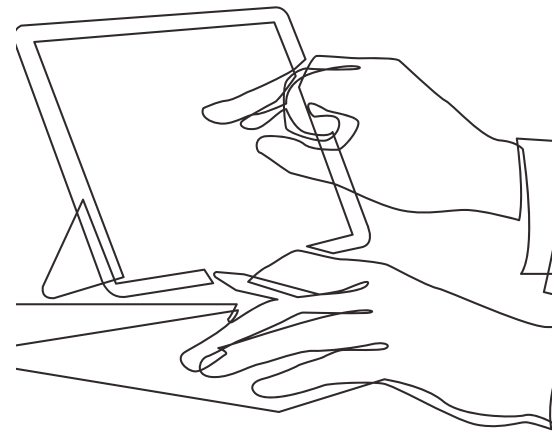

*It’s a good idea to space your requests out rather than requesting all three reports at the same time. That way, you can develop the habit of monitoring your credit report on a regular basis. Monitoring your credit reports also helps to guard against identity theft.*

## Menu

- 1 Are You Financially Ready to Rent?
- 2 The Ins & Outs of Credit
- 3 How to Find the Right Place
- 4 Handling the Application Process
- 5 Understanding the Lease Agreement
- 6 Getting Back Your Security Deposit
- 7 Life as a Renter: Rights & Responsibilities
- 8 Housekeeping, Maintenance & Repairs
- 9 The Right Way to Terminate the Lease

# How to Request Your Credit Report

It's easy to request your credit report. Choose any of the following:

## Online at AnnualCreditReport.com

Visit AnnualCreditReport.com to see, print and download your credit report.

## Complete a Phone Verification

Call 877-322-8228 and complete a simple verification process. You'll need to allow two to three weeks for delivery of your credit report.

## Complete a Request Form

Download a request form at AnnualCreditReport.com. Print out, fill in and mail your completed form to:

## Annual Credit Report Request Service

P.O. Box 105281, Atlanta, GA 30348-5281

Credit reports are still the number one tool used by creditors to determine creditworthiness. A consumer must give written or verbal permission for their credit report to be accessed.

Requesting a report from a credit reporting agency is really a straightforward process. The credit report may take some time to understand, but then it becomes pretty simple to read. You can view a sample credit report on the Resources tab. The next section will talk you through the process of reading the information contained in the credit report.

# Reading a Credit Report

So, what does your credit report say about you? It can seem intimidating at first glance, but reading your credit report is really simple once you understand how it's put together.

Here's how it works: Each credit report contains five main sections: Personal Information, Public Information, Collection Accounts, Creditor Information and Inquiry.

**The Personal Information section** always includes your name(s), address and Social Security number. Other information, such as employment history and birth date, may also be included. It's important to review all information carefully to be sure it is being reported accurately.

## Menu

- 1 Are You Financially Ready to Rent?
- 2 The Ins & Outs of Credit
- 3 How to Find the Right Place
- 4 Handling the Application Process
- 5 Understanding the Lease Agreement
- 6 Getting Back Your Security Deposit
- 7 Life as a Renter: Rights & Responsibilities
- 8 Housekeeping, Maintenance & Repairs
- 9 The Right Way to Terminate the Lease



*If you have a suffix associated with your name, such as Jr., always use it when applying for credit or signing other legal documents. This simple step helps ensure positive identity and prevents potential mix-ups with the report of the person for whom you are named.*



This section shows any credit-related issues processed through the court systems. This could include:

- ▶ Judgments.
- ▶ Tax liens.
- ▶ Bankruptcies.
- ▶ Other debt, including federal debt, child support obligations or rental agreements.

These negative entries on an individual’s credit report could stop a rental application from being approved. A HUD Housing Counseling Agency can often assist individuals in creating a budget and working out a repayment plan, if applicable.

- ▶ **Judgments.** If a debt goes unpaid, the creditor can ask the courts to intervene. When the judge rules in favor of the creditor, a judgment is granted. Judgments remain on a credit report for a minimum of seven years from the date filed.
- ▶ **Tax liens.** This is a legal action taken by a government entity against an individual for delinquent monies owed and can’t be released until paid. Whether federal or state, the lien will appear on a credit report.
- ▶ **Bankruptcy.** This legal procedure is designed to protect both an individual who can’t meet their financial obligations and the creditors involved.
  - Chapter 7 Bankruptcy (known as a straight bankruptcy) wipes out all debt included in the discharge and stays on a credit report for 10 years from date of discharge.

<h1>Menu</h1>	
<b>1</b>	Are You Financially Ready to Rent?
<b>2</b>	The Ins & Outs of Credit
<b>3</b>	How to Find the Right Place
<b>4</b>	Handling the Application Process
<b>5</b>	Understanding the Lease Agreement
<b>6</b>	Getting Back Your Security Deposit
<b>7</b>	Life as a Renter: Rights & Responsibilities
<b>8</b>	Housekeeping, Maintenance & Repairs
<b>9</b>	The Right Way to Terminate the Lease

# Menu

- 1 Are You Financially Ready to Rent?
- 2 The Ins & Outs of Credit
- 3 How to Find the Right Place
- 4 Handling the Application Process
- 5 Understanding the Lease Agreement
- 6 Getting Back Your Security Deposit
- 7 Life as a Renter: Rights & Responsibilities
- 8 Housekeeping, Maintenance & Repairs
- 9 The Right Way to Terminate the Lease

- **Chapter 13 Bankruptcy** (known as wage earner’s bankruptcy) is a reorganization of debt and stays on a credit report for seven years from date of filing. In this type of bankruptcy, the consumer lists all creditors with an attorney, who then files the paperwork with the bankruptcy court. At the time of filing, all interest stops accruing on the debt. A Trustee (attorney) is assigned by the bankruptcy court to decide what payments must be made for what period of time in order to repay the listed debt. Payments are made to the Trustee, who then sends the funds to each creditor.

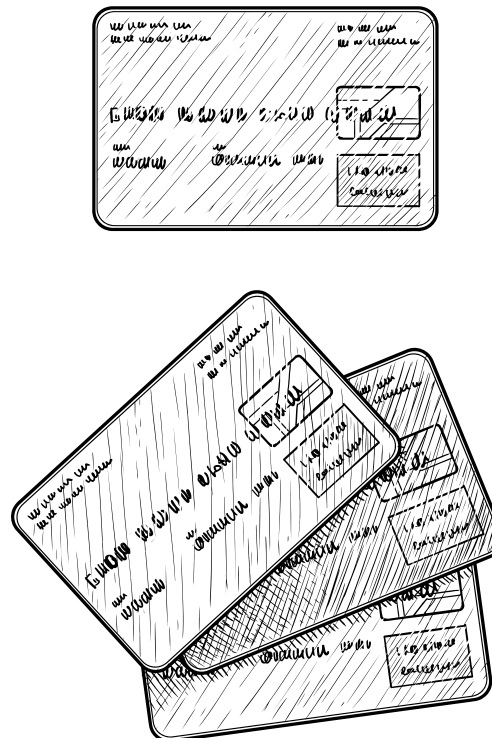

- ▶ **Other Debt.** Defaulted student loans may affect application approval. If so, the landlord may request that the debt be brought current. You might also consider applying for a rehabilitation loan. If you make on-time payments toward your rehabilitation loan for 12 months, the lender of the student loan must erase all negative marks on your credit reports for the defaulted student loan(s).

If you’re behind in child support that is paid to the Division of Child Support Enforcement, the delinquent amount may be reported on your credit history. If you are in arrears, you may be unable to qualify for rental housing until your delinquency is paid in full.



*It’s important to retain all paperwork regarding transactions and payment history for any delinquent child support.*



# Menu

- 1 Are You Financially Ready to Rent?
- 2 The Ins & Outs of Credit
- 3 How to Find the Right Place
- 4 Handling the Application Process
- 5 Understanding the Lease Agreement
- 6 Getting Back Your Security Deposit
- 7 Life as a Renter: Rights & Responsibilities
- 8 Housekeeping, Maintenance & Repairs
- 9 The Right Way to Terminate the Lease

## Collection Accounts

This section lists debts a creditor sold to a collection agency or debt collected by the original creditor when an account became past due. The U.S. Fair Credit Reporting Act of 1997 requires the credit reporting agency to provide specific account information including:

- ▶ The original creditor.
- ▶ Date the account was purchased.
- ▶ Amount of debt that was purchased.
- ▶ A portion of the original account number.

A collection account remains on a credit report for seven years from the date of last activity, which could be either the date of the account transfer or the date of the last payment.

## Revolving, Installment and Mortgage Accounts

This section includes an updated report provided each month by most creditors to one or more of the three major credit-reporting agencies. Reported information may include:

- ▶ Account balance.
- ▶ Available credit.
- ▶ Scheduled payments.
- ▶ Actual payment.
- ▶ High credit.
- ▶ Credit limit and amount past due.

Account details include the:

- ▶ Terms.
- ▶ Months reviewed.
- ▶ Loan type.
- ▶ Balloon payment date.
- ▶ Deferred payment start date.
- ▶ Months reviewed.
- ▶ Date of last activity.
- ▶ Date of the first delinquency.

Along with a comment section.

All creditor information remains on your credit report for seven years from the date of last activity.



*If you notice an account that has been paid in full is still showing a balance, you should check the “date last reported” and “date of last activity” to make certain the information has been updated.*



## Ownership of the Account

Each creditor lists the type of ownership:

**A = Authorized User.** An authorized user is permitted, by the person responsible for paying the debt, to make charges on a credit account, but is not responsible for repayment.

**I = Individual.** Only one individual is responsible for repayment.

**J = Joint.** Two or more individuals are responsible for repayment. In the case of a divorce and joint credit, anyone who has signed to be responsible for payment retains that responsibility, even if a court has ordered a specific individual to pay the debt. If the court-ordered individual fails to pay as agreed, the late payment may be on the credit history for both individuals. The best thing to do is to close all joint accounts and open new credit as an individual. Sometimes, due to financial circumstances, this isn't possible. When this is the case, the individual who hasn't been court ordered might request that a creditor notify them if a payment is late.

## Account Types

This rating system describes the type of credit and the way in which the obligation has been paid. The account types consist of:

- ▶ **R = Revolving Credit.** This is a line of credit that can be borrowed from more than once, such as a credit card.
- ▶ **I = Installment.** This is a loan with a specific payment for a specific period of time, such as a car loan.
- ▶ **O = Open account.** This is an obligation that must be paid in full every 30 days.

*January*

S	M	T	W	T	F	S
	1	2	3	4	5	6
7	8	9	10	11	12	13
14	15	16	17	18	19	20
21	22	23	24	25	26	27
28	29	30	31			

# Menu

- 1 Are You Financially Ready to Rent?
- 2 The Ins & Outs of Credit
- 3 How to Find the Right Place
- 4 Handling the Application Process
- 5 Understanding the Lease Agreement
- 6 Getting Back Your Security Deposit
- 7 Life as a Renter: Rights & Responsibilities
- 8 Housekeeping, Maintenance & Repairs
- 9 The Right Way to Terminate the Lease

## Rating Status

A good credit history is important when seeking application approval. The way in which you've paid past obligations is believed to be an accurate indication of how you may handle future ones.

## Inquiries

There are two types of inquiries — hard and soft. Hard inquiries may impact your credit score, while soft inquiries do not impact your credit score. This section lets you know that a creditor accessed your credit history and the date when this occurred. Inquiries remain on your credit history for two years. Some inquiries will have notations indicating the creditor has not viewed your credit history.

These include:

The credit rating section consists of:	
OK	Paid as Agreed/current
30	Account 30 days past due
60	Account 60 days past due
90	Account 90 days past due
120	Account 120 days past due
150	Account 150 days past due
180	Account 180 days past due
C	Collection Account
CO	Charge-off
R	Repossession
V	Voluntary Surrender
B	Bankruptcy
TN	Too New To Rate
ND	No Data Available

- ▶ **PRM** (promotional) which means the credit reporting agency has sold your name and address to businesses to be used for marketing purposes. This is typically why you receive all those direct mail solicitations for new credit card accounts. It does count as an inquiry, but it doesn't count against your credit score.
- ▶ **AR** (annual review) means a current creditor has viewed your credit as part of their annual review process. However, while this does count as an inquiry, it doesn't count against your credit score.



*Note: When an insurance company or a prospective employer views your credit history, this doesn't count as an inquiry as long as those entities use the proper coding. You'll understand the importance of keeping inquiries to a minimum when credit scoring is discussed.*

# Menu

- 1 Are You Financially Ready to Rent?
- 2 The Ins & Outs of Credit
- 3 How to Find the Right Place
- 4 Handling the Application Process
- 5 Understanding the Lease Agreement
- 6 Getting Back Your Security Deposit
- 7 Life as a Renter: Rights & Responsibilities
- 8 Housekeeping, Maintenance & Repairs
- 9 The Right Way to Terminate the Lease

## Other Components of a Credit Report

Credit reports may also include a Consumer Statements section, information on how to file a dispute, a summary of your rights under the Fair Credit Reporting Act, and your rights under state law. More details will be provided in the next section.

Even if you've had credit problems in the past, you may still be eligible to rent. The landlord will consider the circumstances surrounding the problems, how long ago the negative credit occurred and if you've paid your obligations on time since then.



*Consider requesting a copy of your credit report from the credit reporting agencies before submitting a rental application. Remember, every time you apply for credit your score is impacted.*

## Summary

A snapshot of your credit report includes the date of the report, average account age, credit history length, number of accounts with negative information, and your most recent and oldest accounts.

## Explanations

Credit reporting agencies will allow consumers to include up to a 100-word explanation if you disagree or would like to provide more details about information stated in your credit report. The explanation will appear in the Consumer Statements section of your credit report.

# Disputing Incorrect Credit Report Information

Under the Fair Credit Reporting Act of 1997, you have the right to dispute incorrect information on your credit report by requesting the credit reporting agency to investigate.

A summary of your FCRA rights are provided with your credit report. The Act promotes the accuracy, fairness and privacy of information in your file.

## Menu

- 1 Are You Financially Ready to Rent?
- 2 The Ins & Outs of Credit
- 3 How to Find the Right Place
- 4 Handling the Application Process
- 5 Understanding the Lease Agreement
- 6 Getting Back Your Security Deposit
- 7 Life as a Renter: Rights & Responsibilities
- 8 Housekeeping, Maintenance & Repairs
- 9 The Right Way to Terminate the Lease

Because each credit reporting agency may have different information, you must file a separate dispute for the same error with all three agencies. Once the credit reporting agency receives your dispute, it has 10 days to get the information to the creditor. The creditor then has approximately 30 days to respond. If the creditor can't provide documentation to the credit reporting agency that proves the reported information is valid, the disputed item will be removed from your credit report, and you'll receive notification of the action taken.

It's possible the creditor may, at a later date, be able to prove the validity of the original information, and it will be placed back on your credit history.



*Be sure to keep all paperwork relating to any dispute you file with the credit reporting agencies, and never mail your original receipts or other documentation.*

*If the credit reporting agencies verify that their information is accurate, they will notify you. If you still believe there is an error, you can ask for another investigation. If the second investigation is not in your favor, you can ask that a 100-word explanation be inserted next to the erroneous entry on your credit report to explain your side.*

### **How to Handle Incorrect Credit Report Information**

Dispute forms can be obtained by phone, mail or the internet. Your credit report will provide a How to Dispute Inaccurate Information section. If you need assistance to prepare a dispute, please contact a HUD Housing Counseling Agency.

You've learned ways to handle incorrect information on your credit report. Now, let's review how you might handle unwanted phone calls and junk mail to eliminate unsolicited information

### **State Laws – Security Freeze**

Virginia consumers have a right to place a “security freeze” on their credit report. The freeze is designed to prevent credit, loans and services from being approved in your name without your consent. More information is provided in the Your Rights Under State Law section of your credit report. Read this document in its entirety to understand the pros and cons of a security freeze.

## Menu

- 1 Are You Financially Ready to Rent?
- 2 **The Ins & Outs of Credit**
- 3 How to Find the Right Place
- 4 Handling the Application Process
- 5 Understanding the Lease Agreement
- 6 Getting Back Your Security Deposit
- 7 Life as a Renter: Rights & Responsibilities
- 8 Housekeeping, Maintenance & Repairs
- 9 The Right Way to Terminate the Lease

# Unwanted Phone Calls and Junk Mail

If you'd like to reduce, if not completely eliminate, unwanted credit card and other solicitations, you have the legal right to opt out.

Here are a few options:

## Pre-screened mailing lists:

To have your name removed from pre-screened mailing lists and insurance offer mailing lists provided to creditors and others, contact Experian, Equifax and TransUnion by calling 888-5OPT-OUT (888-567-8688) or by visiting [optoutprescreen.com](http://optoutprescreen.com).

You'll be given the choice to opt out for two years or permanently. To permanently opt out, you'll need to request a Permanent Opt-Out Election form. When you receive the form, you must sign and return it, otherwise your opt out won't be activated.

## Telemarketing call lists:

- ▶ Thanks to the National Do Not Call Registry and the Do-Not Call Improvement Act of 2007, you can stop most telemarketing calls. You may opt out your home and/or cell phone numbers permanently. Remember, you must call from the phone number you want to be removed. To do this, call 888-382-1222 or visit [donotcall.gov](http://donotcall.gov).

## Direct mailing services lists:

You can also limit unwanted mail and phone calls you may receive that aren't related to the lists credit reporting agencies sell to creditors, lenders and other business. You may opt out for 10 years for a \$2 fee by visiting [dmachoice.org](http://dmachoice.org).

# Managing and Reducing Debt

A credit score is the number from 300 to 850 that represents the risk of lending money to you. Credit scores cannot predict, with certainty, how you or anyone will act. They do provide a quick and objective indication of how likely you are to repay on time and according to terms, based on how you've handled your credit in the past.

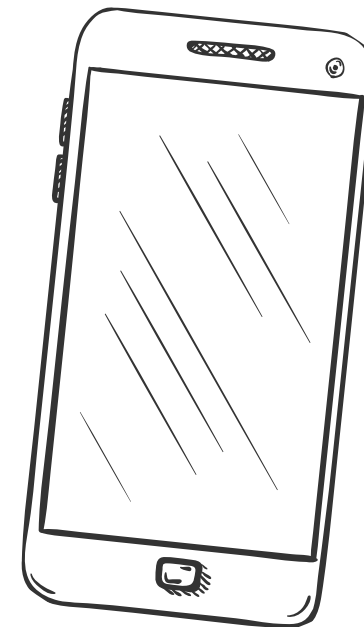

## Menu

- 1 Are You Financially Ready to Rent?
- 2 The Ins & Outs of Credit
- 3 How to Find the Right Place
- 4 Handling the Application Process
- 5 Understanding the Lease Agreement
- 6 Getting Back Your Security Deposit
- 7 Life as a Renter: Rights & Responsibilities
- 8 Housekeeping, Maintenance & Repairs
- 9 The Right Way to Terminate the Lease



It is important to understand there are different credit-scoring models. Two popular models are:

- ▶ The VantageScore, which is what consumers receive when they purchase a credit report and score through one of the three credit reporting agencies.
- ▶ **The FICO score** which is believed to provide the best guide to assess future risk. The FICO score grades more than just payment delinquency. It's also influenced by things like the percentage of loan balances to loan amounts, the number of consumer finance accounts, and even the number of credit cards shown as open.

Although both models mentioned here evaluate similar information, the scores provided won't be exactly the same. This is because, as discussed earlier, not every creditor reports to an agency and not all creditors who report information do so with all three major agencies. The result is three different reports and scores for each individual.

## How is the Credit Score Determined?

The credit score is determined by the following factors. Select each button to reveal more details about the factor and, when finished, click Next to continue.

- ▶ 35% is based on Payment History. Your past 12-month history is the most important.
- ▶ **30% is based on Amounts Owed.** This is the extent to which your credit lines have been accessed. If you have several credit cards with maximum limits that have been reached or almost reached, that will have a negative impact on your credit score. It's recommended that you not exceed 30% of your available credit lines.
- ▶ **15% is based on Length of Credit History.** Ask a HUD Housing Counseling Agency to review your credit profile before making changes that can negatively affect your credit history, such as closing unused credit card accounts or consolidating debt. These types of changes can potentially remove positive account information.
- ▶ **10% is based on New Credit.** Numerous inquiries for new credit can affect your credit score by making it seem that you are trying to gain additional credit. This

## Menu

1	Are You Financially Ready to Rent?
2	The Ins & Outs of Credit
3	How to Find the Right Place
4	Handling the Application Process
5	Understanding the Lease Agreement
6	Getting Back Your Security Deposit
7	Life as a Renter: Rights & Responsibilities
8	Housekeeping, Maintenance & Repairs
9	The Right Way to Terminate the Lease



is why it isn't wise to take advantage of store discounts in exchange for completing a credit application if all you want to do is save a few dollars on your purchases for a specific day.

- ▶ **10% of your score is based on Types of Credit Used.** Having a mix that includes both secured credit and unsecured credit may be beneficial.

## How to Get Your Credit Score

Although you can purchase your credit score from any or each of the major credit reporting agencies, you may want to consider purchasing the score from the agency that covers the area where you have spent most of your adult life.

While landlords are allowed to share your credit score and credit history with you, individual landlords have their own guidelines regarding this practice. You can also purchase your FICO credit score from [myfico.com](https://myfico.com).

Your credit score is extremely important to financial success. Let's take a look at how to establish credit to ensure you have a good credit score.

## Establishing Credit

Establishing credit can be a challenge, even a Catch-22. Creditors will not grant you credit because you haven't established a financial record of paying creditors on time; you can't establish a financial record until a creditor grants you credit. Start by opening a checking and/or savings account with your local bank or credit union. Then inquire about a secured credit card.

A secured credit card is treated like a regular credit card, but with a few differences. With the secured credit card, the holder must initially deposit personal funds to open the account. For example, if you open a secured credit card and make a deposit of \$500, there will be a minimum of \$500 available to charge. (Please visit your financial institution to see all the options they may offer.)

## Menu

- 1 Are You Financially Ready to Rent?
- 2 The Ins & Outs of Credit
- 3 How to Find the Right Place
- 4 Handling the Application Process
- 5 Understanding the Lease Agreement
- 6 Getting Back Your Security Deposit
- 7 Life as a Renter: Rights & Responsibilities
- 8 Housekeeping, Maintenance & Repairs
- 9 The Right Way to Terminate the Lease

# Menu

- 1 Are You Financially Ready to Rent?
- 2 The Ins & Outs of Credit
- 3 How to Find the Right Place
- 4 Handling the Application Process
- 5 Understanding the Lease Agreement
- 6 Getting Back Your Security Deposit
- 7 Life as a Renter: Rights & Responsibilities
- 8 Housekeeping, Maintenance & Repairs
- 9 The Right Way to Terminate the Lease

Many financial institutions will place your deposit into an interest-bearing account to be used as collateral against any future credit card charges. Once you've received your secured credit card, be careful to make only necessary purchases and avoid careless charges. The deposit you made up front will stay in your account until you close your account, upgrade to an unsecured credit card or default on your credit card balance.

Let the landlord know if you have little or no traditional credit history. Some landlords may give you the opportunity to use alternatives that demonstrate financial responsibility. Paying daycare providers, utilities and other recurring obligations (typically not reported to the CRAs) may be considered by some landlords. In addition, offering direct deduction from your personal bank account or your employer's payroll may help as well.

The first step on the road to a really good score is to establish a credit score. Over time, you may find that you may need to improve your score, which is what we will address in the next section.

## Ways to Improve Your Credit Score

You may want to improve your credit score now so that when it comes time to rent, you'll have a better chance of qualifying for an apartment. Here are some proven ways you can do this:

- ▶ Pay your bills on time.
- ▶ Keep your total credit card balances to no more than 50% of your total debt.
- ▶ Pay down the balances on your credit cards.
- ▶ Don't apply for more credit.
- ▶ Never co-sign for any financial account with a friend or relative.
- ▶ Regularly review your credit report for errors.

Your score will improve as you continue to handle your credit obligations responsibly. Think of a credit score as a snapshot of your credit risk, reflecting your risk picture at a specific point in time.



*Don't pay any agency to "repair" your credit. There is nothing they can accomplish on your behalf that you can't do yourself. You can improve your credit on your own with time, assistance from a credit or HUD Housing Counseling Agency, better credit behavior and a focused effort on removing inaccurate information.*

## Working With Housing, Credit and Financial Counselors

If you have problems with too much debt and could use some help with managing your money, be careful. Not all housing and credit counseling organizations are nonprofit. A good place to look for a reputable counseling organization is the Department of Housing and Urban Development (HUD) website. It lists HUD-approved housing counseling agencies by state. You can visit their website at [hud.gov](http://hud.gov) to locate an agency near you or call 800-569-4287 toll free.

The National Foundation for Credit Counseling® (or NFCC®) is another resource to find certified consumer credit counselors. Visit their website at [nfcc.org](http://nfcc.org).



*Many of these agencies also provide assistance and guidance with money management, credit and budgeting after you've bought your home. Be sure to ask.*



## Menu

- 1 Are You Financially Ready to Rent?
- 2 The Ins & Outs of Credit
- 3 How to Find the Right Place
- 4 Handling the Application Process
- 5 Understanding the Lease Agreement
- 6 Getting Back Your Security Deposit
- 7 Life as a Renter: Rights & Responsibilities
- 8 Housekeeping, Maintenance & Repairs
- 9 The Right Way to Terminate the Lease

# Avoiding Identity Theft

Identity theft happens when predators dumpster-dive, “phish” or otherwise gain access to your personal information. In fact, the FBI reports that identity theft is one of the nation’s fastest-growing crimes, making it very important to safeguard your personal information. Here are some areas that need to be looked at to ensure the safety of your personal information.

## Social Security Number

- ▶ Always protect your Social Security number.

## Document Security

- ▶ Don’t carry rarely used documents, such as your birth certificate and Social Security card, with you.
- ▶ Use a cross-cut shredder to destroy documents containing sensitive information.

## Credit Report and Issuers

- ▶ Review your credit report regularly for suspicious activity.
- ▶ Keep a list of contact information for credit issuers.

## Password Protection and Lost Cards

- ▶ Don’t use common passwords, such as birth dates, for ATM, computer and other electronic access.
- ▶ Report lost or stolen cards immediately.

## Mail Maintenance

- ▶ Be aware of mail or bills that don’t arrive on time or unfamiliar credit application responses.
- ▶ When mailing payments, put them directly in a U.S. postal box instead of your home mailbox.
- ▶ Install a lock on your home mailbox.
- ▶ Obtain a P.O. box or temporarily stop mail delivery when you know you’ll be away for longer than a weekend.

## Printed Checks

Don’t include Social Security or phone numbers when ordering printed checks.

- ▶ Have ordered checks delivered to your bank and pick them up there.

## Menu

- 1 Are You Financially Ready to Rent?
- 2 The Ins & Outs of Credit
- 3 How to Find the Right Place
- 4 Handling the Application Process
- 5 Understanding the Lease Agreement
- 6 Getting Back Your Security Deposit
- 7 Life as a Renter: Rights & Responsibilities
- 8 Housekeeping, Maintenance & Repairs
- 9 The Right Way to Terminate the Lease

Identity theft is serious. It is important that you practice all of the strategies mentioned here to avoid becoming a victim. Criminals are vigilant and may even find a way to attack you even if you have been safe. The next section discusses what to do if identity theft happens to you.

## What to Do if You Become a Victim of Identity Theft

If you discover you're a victim of identity theft, it is extremely important that you act quickly:

- ▶ Immediately contact the companies directly, and close accounts that have been tampered with or opened fraudulently.
- ▶ Report the identity theft to the appropriate law enforcement agency.
- ▶ Consider placing a Fraud Alert on your profile by contacting any of the credit reporting agencies. A fraud alert can make it more difficult for someone to get credit in your name because it tells creditors to follow certain procedures to protect you. (The flip side is that the alert also may delay your ability to obtain credit.)

**An initial fraud alert** stays in your file for at least 90 days.

**An extended alert** stays in your file for seven years.



*To place either of these alerts, a consumer credit reporting company will require you to provide appropriate proof of your identity, which may include your Social Security number. If you ask for an extended alert, you'll also be required to provide a copy of the identity theft report you filed with your local, state or federal law enforcement agency.*



**Test Your Knowledge.** Take the quiz for this chapter and get a certificate of completion! You'll be asked to create a user login, if you haven't already: <https://VirginiaHousinglearningcenter.mkscloud.com>

## Menu

- 1 Are You Financially Ready to Rent?
- 2 The Ins & Outs of Credit
- 3 How to Find the Right Place
- 4 Handling the Application Process
- 5 Understanding the Lease Agreement
- 6 Getting Back Your Security Deposit
- 7 Life as a Renter: Rights & Responsibilities
- 8 Housekeeping, Maintenance & Repairs
- 9 The Right Way to Terminate the Lease



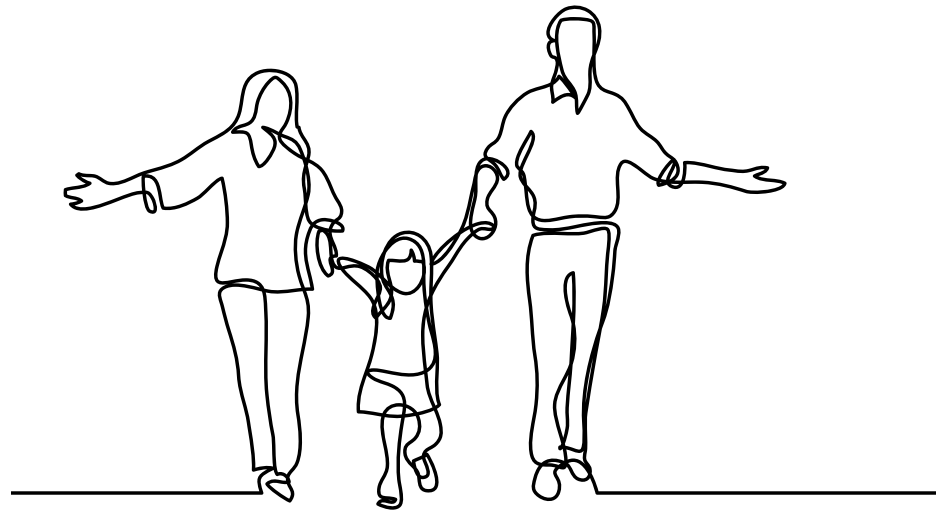

# Chapter 3

## How to Find the Right Place

Searching for just the right place to call home can be stressful, time-consuming and even overwhelming at times. Knowing how many bedrooms, baths and other amenities you want is just the beginning. Your price range and desired community is equally important when exploring the rental market.

It's important to know the different types of residential rental properties and their basic characteristics. You have significant options to consider, depending on whether you're looking for a traditional apartment complex, a detached home, a mixed-use community, subsidized housing, a studio apartment or simply a room to rent. Understanding the lease terms and conditions of each option will help you make the right decisions. Whether looking on your own or with the assistance of a housing professional, remember that you have legal rights. Know your rights before inquiring about any available rental property.

## Menu

- 1 Are You Financially Ready to Rent?
- 2 The Ins & Outs of Credit
- 3 How to Find the Right Place
- 4 Handling the Application Process
- 5 Understanding the Lease Agreement
- 6 Getting Back Your Security Deposit
- 7 Life as a Renter: Rights & Responsibilities
- 8 Housekeeping, Maintenance & Repairs
- 9 The Right Way to Terminate the Lease

# Fair Housing Laws

Virginia enforces a Fair Housing Law that is substantially derived from the Federal Fair Housing Act. When you're looking for an apartment or buying a home, the law protects you from bias. If you're working with a property manager, real estate agent, landlord or owner to find or acquire a rental home, or if you're trying to obtain renters insurance, you cannot be treated differently from others. The law prohibits rental transactions that discriminate.

## Protecting Against Housing Discrimination

Like the federal law, the Virginia Fair Housing Law defines protected classes of individuals to shield them from discriminatory practices, stating that no one can be denied housing because of:

- ▶ Race
- ▶ Color
- ▶ Religion (any or none)
- ▶ Gender
- ▶ Disability (handicap to include hoarding)
- ▶ Elderliness (individuals age 55 or older, as covered in Virginia state law)
- ▶ Familial status
- ▶ National origin
- ▶ Source of income
- ▶ Veteran status
- ▶ Gender identity
- ▶ Sexual orientation

Historically, race, disability and familial status have been common housing discrimination complaints. Familial status means having children under 18 in the family, pregnant women or adults attempting to secure custody of children. With the exception of senior communities (over 55 or 62) or retirement facilities, refusing to rent to families with children is illegal. However, in some cases there are general guidelines for occupancy standards, allowing two people per bedroom. Dictating which bedroom children of different sexes should sleep in, or what floor(s) families with children should live on, is prohibited.

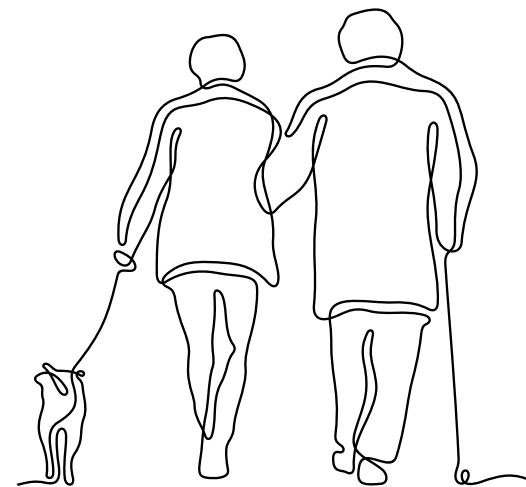

*There are also nonprotected classes under the Fair Housing Act. However, there may be protection under a local ordinance for students, smokers and marital status (unmarried couples).*

## Menu

- 1 Are You Financially Ready to Rent?
- 2 The Ins & Outs of Credit
- 3 How to Find the Right Place
- 4 Handling the Application Process
- 5 Understanding the Lease Agreement
- 6 Getting Back Your Security Deposit
- 7 Life as a Renter: Rights & Responsibilities
- 8 Housekeeping, Maintenance & Repairs
- 9 The Right Way to Terminate the Lease

## Prohibited Rental Practices

The law prohibits the refusal to accept, consider, negotiate, process or accurately communicate a bona fide offer because of any of the 12 protected classes under Virginia law. In general, prospective renters are protected from several prohibited rental practices.

### Misrepresentation of Available Dwelling

Representing that any dwelling is not available for rent when such dwelling is, in fact, available.

### Different Qualification Criteria

Using different qualification criteria, applications or rental standards or procedures.

### Inducing

Inducing (or attempting to induce) to rent any dwelling by representations regarding the entry or prospective entry into the neighborhood.

### Incompatibility of Renter with Neighborhood

Communicating to a renter that they would not be comfortable or compatible with existing residents of a community neighborhood or development.

### Assigning Renter to a Particular Area

Assigning a prospective renter to a particular section of the development, particular floor or section of a building.

### Discriminating

This includes discriminating against any individual in the terms, conditions or privileges, services and facilities.

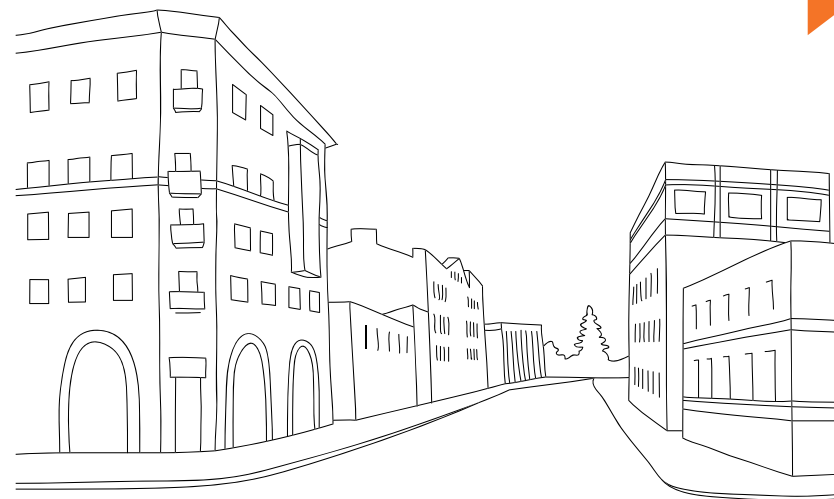

# Menu

- 1 Are You Financially Ready to Rent?
- 2 The Ins & Outs of Credit
- 3 How to Find the Right Place
- 4 Handling the Application Process
- 5 Understanding the Lease Agreement
- 6 Getting Back Your Security Deposit
- 7 Life as a Renter: Rights & Responsibilities
- 8 Housekeeping, Maintenance & Repairs
- 9 The Right Way to Terminate the Lease

The Fair Housing Board administers and enforces the law and investigates complaints of discrimination through the Virginia Fair Housing Office. If you think you've been discriminated against when trying to rent an apartment or home, you can file a complaint.

**Virginia Fair Housing Office**  
9960 Mayland Drive, Suite 400  
Richmond, VA 23233-1463  
Phone: 804-367-8530 or (888) 551-3247  
TDD: Virginia Relay 7-1-1  
FAX: 866-480-8333  
Website: [dpor.virginia.gov](http://dpor.virginia.gov)  
Email: [FairHousing@dpor.virginia.org](mailto:FairHousing@dpor.virginia.org)

## Needs vs. Wants

Before you begin looking for the right rental home for you, it's important to identify what is needed, and what you want because it would be nice to have, in your future home. A key step that could help narrow down the number of properties to see and, ultimately, save you time is to make a list. Here are a few things to consider:

**Price.** How much can you afford to spend on rent? Developing your Spending and Savings Plan will help you figure out the maximum or a comfortable amount you can afford to spend for rent, utilities and other housing costs. Rental prices can vary significantly depending on the fair market rent for the area. **Fair market rent** varies by the economy and geographic areas. The Department of Housing and Urban Development (HUD) uses fair market rent with their various rental housing programs.

Which utilities (if any) are included in the monthly rent can vary as well. Because the cost of utilities could be your second-highest housing expense, you'll want to know your maximum rent amount with and without utilities. Checking with the utility company to get a cost history can be very helpful. They can give you a printout of the previous occupants' usage history to help you anticipate and prepare for future cost.

## Menu

- 1 Are You Financially Ready to Rent?
- 2 The Ins & Outs of Credit
- 3 How to Find the Right Place
- 4 Handling the Application Process
- 5 Understanding the Lease Agreement
- 6 Getting Back Your Security Deposit
- 7 Life as a Renter: Rights & Responsibilities
- 8 Housekeeping, Maintenance & Repairs
- 9 The Right Way to Terminate the Lease

**Size.** Of course, most of us would prefer the largest unit possible. The overall size of a dwelling is measured in square footage and is a good way to compare the size of different units. After determining your price range, shop around. Keep in mind that larger units could mean higher utility bills.

**Number of bedrooms.** How many bedrooms you want and how many you need may not be the same number. In fact, we all would like that extra bedroom for guests or maybe as an office space. However, consider the cost burden that extra bedroom may have on your overall household budget and comfort level. Could it eventually cause financial problems? Remember, as the number of bedrooms increases, so does the amount of your rent.

In some cases, federal, county and city Compliance Departments have maximum occupancy laws, regulations and requirements that limit occupancy to two people per bedroom.

**Location.** There are a lot of personal factors to consider when narrowing the location of where you prefer to live. A rental home located in the inner city, suburbs or a rural neighborhood may be important to you. Or perhaps living closer to work, schools or your church is more important. Knowing in advance your desired location will help you better define your search.

**Proximity to amenities.** Are there conveniences that you need or want to be close to? For example, if you plan to take public transportation to and from work, it may be necessary to live near bus or light rail stops. If you enjoy spending time outdoors with your children, you may want to live near city parks. Identifying the importance of these types of amenities and their proximity to the possible rental home can be an important factor in your housing search.

**Pet-friendly.** Do you have a beloved animal member of your family? The decision to allow pets is strictly up to the landlord, and many landlords are not pet friendly. Those who do allow pets have different rules regulating what kind of pet, the breed, the size and number of pets allowed. Additional financial commitments are often associated with pet-friendly dwellings that can include pet rents, pet deposits and damage fees. Look for ads like the ones listed below if a pet-friendly dwelling is one of your priorities.

## Menu

- 1 Are You Financially Ready to Rent?
- 2 The Ins & Outs of Credit
- 3 How to Find the Right Place
- 4 Handling the Application Process
- 5 Understanding the Lease Agreement
- 6 Getting Back Your Security Deposit
- 7 Life as a Renter: Rights & Responsibilities
- 8 Housekeeping, Maintenance & Repairs
- 9 The Right Way to Terminate the Lease



# Menu

- 1 Are You Financially Ready to Rent?
- 2 The Ins & Outs of Credit
- 3 How to Find the Right Place
- 4 Handling the Application Process
- 5 Understanding the Lease Agreement
- 6 Getting Back Your Security Deposit
- 7 Life as a Renter: Rights & Responsibilities
- 8 Housekeeping, Maintenance & Repairs
- 9 The Right Way to Terminate the Lease

- ▶ No Pets Allowed
- ▶ Cats or Dogs Allowed
- ▶ Cats and Small Dogs Allowed (Weight Limit)
- ▶ Cats and Dogs Allowed (Breed Restrictions)
- ▶ Cats and Dogs Allowed (One per Unit)

You should ask the landlord up front, and at any time during your tenancy, about other pets such as birds, turtles, rabbits and snakes before planning to bring them into your rental home.

Breed restriction often refers to dogs considered an insurance liability. The landlord and the renter (if trying to acquire renters insurance) will find it difficult, if not impossible, to obtain insurance coverage. Higher, more costly insurance premiums can be charged for dog breeds like pit bull, German Shepherd, rottweiler and Doberman.



*A service animal is not a pet. The ADA requires landlords to make an exception for an applicant with a trained animal that provides assistance to the applicant or their household member with a disability.*

- ▶ **Outdoor space.** Whether you simply like to entertain or need space for children to play, outdoor space can be high on the list of priorities for many renters. Keep in mind that the amenity of outdoor space may come with added responsibility, such as lawn care.
- ▶ **Laundry facilities.** What's your laundry preference? Do you own a washer and dryer and simply need to find a rental that offers washer and dryer hookups? Or do you want to live in an apartment complex that offers on-site laundry accommodations?
- ▶ **Parking.** Ask yourself, what do I consider adequate parking? The answer will vary. Even if you don't have a car, you may want to consider the parking conditions for guests. It's not uncommon for rental properties to impose restrictions or limitations on parking. One space per unit, assigned parking spaces for each unit and assigned parking for a resident's guest are examples of parking restrictions. Some larger apartment complexes may issue permanent decals for residents and temporary passes for guests.

Parking violators risk fines and the possibility of having their vehicle towed. It is the responsibility of the renter to inform their guests of parking restrictions or provide any applicable guest passes.

- ▶ **Desired moving date.** Do you need to find a rental quickly, or do you have time to shop around? Time constraints may limit your options. In some cases, a highly desired apartment complex may have a waiting list. Or, perhaps that single-family home is not available for immediate occupancy. Before you start your search, know your desired move-in date and whether you have any flexibility with that.

In addition, if you're moving from one rental to another, remember that you'll need to give your current landlord sufficient move-out notice.

- ▶ **Other details.** A few other things to consider may be your desire to have hard surface floors versus carpet, central air conditioning, extra closets or storage space, a pool or an energy-efficient unit.

## Rental Search Assistance

One of the most important decisions we make is choosing our housing. Ideally, renters shouldn't spend more than 30% of their income on rent. With this in mind, finding affordable housing — with rent costs that are reasonable compared to the median income for the city or county — can be a serious challenge.

When rent costs are below the median income, the rental market is considered a low-cost rental market. An average-cost rental market is when rent costs are in line with the median income. A high-cost rental market is when rent costs are above the median income for the area. Staying within the 30% rent-to-income recommendation can be tough in a high-rent area. Here are some resources to help you with your search.

## Menu

- 1 Are You Financially Ready to Rent?
- 2 The Ins & Outs of Credit
- 3 How to Find the Right Place
- 4 Handling the Application Process
- 5 Understanding the Lease Agreement
- 6 Getting Back Your Security Deposit
- 7 Life as a Renter: Rights & Responsibilities
- 8 Housekeeping, Maintenance & Repairs
- 9 The Right Way to Terminate the Lease

## Resources

- ▶ **Housing locators** can be a valuable resource to help you identify available rentals that fit your budget and comfort level. These housing professionals are typically tasked with finding available rentals within their service area. Building and maintaining positive relationships with everyone from the smaller independent landlord to the larger management-controlled developments is critical. Helping potential renters locate affordable housing is their primary responsibility — especially for those who have other barriers to renting. Search for a HUD-approved Housing Counseling Agency by visiting [hud.gov](http://hud.gov).
- ▶ **Print publications** such as newspaper ads and magazines are one type of resource. Bulletin board advertisements at public facilities, places of employment and university/college campuses are another source. In addition, many websites can assist with your rental search. Your local paper may offer an online classified database search. Property management and real estate companies often provide a listing of rentals handled through their offices on their websites as well.
- ▶ **VirginiaHousingSearch.com** is a comprehensive housing locator service, sponsored by Virginia Housing. This rapidly growing database lets you look for rental housing throughout the Commonwealth using a wide variety of criteria and special mapping features. The site provides detailed information about rental properties to help you find housing to best fit your needs. The search site can be accessed at no cost, 24 hours a day. A toll-free call center is also available Monday – Friday, 9 a.m. – 8 p.m. EST, at 877-428-8844. Operators speak English and Spanish.
- ▶ **HUD.gov** is the HUD website that has information on low-rent apartments for senior citizens and people with disabilities, as well as families and individuals.
- ▶ **GoSection8.com**. This is the largest rental listing service for the Section 8 housing market. The comprehensive database lets families locate and compare affordable rental homes currently available in their area. The listings are available online as well as through the bilingual call center at 866-466-SEC8 (7328). There is never a charge for family members to access the rental listing.

## Menu

- 1 Are You Financially Ready to Rent?
- 2 The Ins & Outs of Credit
- 3 How to Find the Right Place
- 4 Handling the Application Process
- 5 Understanding the Lease Agreement
- 6 Getting Back Your Security Deposit
- 7 Life as a Renter: Rights & Responsibilities
- 8 Housekeeping, Maintenance & Repairs
- 9 The Right Way to Terminate the Lease



Virginia Housing provides links to HUD median income, federal income limits, and Fair market rents. Visit our website at [VirginiaHousing.com](http://VirginiaHousing.com) to learn more.

## Types of Rental Properties

Types of rental properties throughout Virginia are broad, but fall into a few basic categories: the traditional apartment complex; mixed-used property; efficiency, studio, flat or single-room occupancy (SRO); rental assistance housing; detached property (such as a single-family home); and mobile home. Understanding each of these categories will help you decide on the right rental home for you. Lease agreements (discussed in Chapter 5) can vary depending on the category of property you are renting.

- ▶ **Apartment complex.** A group of buildings that include several individual apartments, generally owned by one entity. The units share common grounds, and often share amenities such as laundry facilities, playgrounds and pools. Low-rise or high-rise complexes may have individual apartments horizontally stacked on several floors. This type of apartment community often has a common entrance and hallway. A complex of this type may have apartments attached vertically or side-by-side. Side-by-side apartments, often known as townhouses, typically have two or more floors and separate private entrances.
- ▶ **Mixed-use property.** A building or buildings with a combination of commercial and residential spaces. These properties typically include a mix of retail storefronts, restaurants, offices and housing, and are designed to be communities where one can live, work and play. Residential spaces are often on the upper floors, with commercial spaces on the lower levels — however, the opposite can be also found in some communities. Mixed-use units may range from traditional apartment floor plans to one-room efficiencies.
- ▶ **Efficiencies, studios and flats.** These terms all refer to a single-room unit with an enclosed bathroom. The unit includes all the essential areas found in a traditional

## Menu

<b>1</b>	Are You Financially Ready to Rent?
<b>2</b>	The Ins & Outs of Credit
<b>3</b>	How to Find the Right Place
<b>4</b>	Handling the Application Process
<b>5</b>	Understanding the Lease Agreement
<b>6</b>	Getting Back Your Security Deposit
<b>7</b>	Life as a Renter: Rights & Responsibilities
<b>8</b>	Housekeeping, Maintenance & Repairs
<b>9</b>	The Right Way to Terminate the Lease

apartment, but with little or no wall division between the areas. The living area, eating area, kitchen and bedroom are all together in one combined space. Typically, efficiencies have a full kitchen, while studios have limited kitchens. Some studio apartments may also feature a loft.

- ▶ **Single-room occupancy (SRO).** An SRO is a boarding or rooming house arrangement, such as a single-family home with one or more rooms for rent. Multiple individuals and/or families live under the same roof. Some rooms for rent have no or limited kitchen use. Some may include meals and other amenities in the rent. Other arrangements may require tenants to share in the maintenance, cleaning and household upkeep. The lease term may be for one or more weeks, one or more months, or for a year.
- ▶ **Rental assistance housing.** Rental assistance programs are available to help low-income families, elderly and disabled renters afford decent, safe and sanitary housing. Often referred to as subsidized housing, qualified tenants pay a portion of the fair market rent for the area. Four types of subsidized rent programs are:
  - **Public housing rentals.** The Department of Housing and Urban Development (HUD) administers federal aid to local housing agencies, such as a public housing authority, to manage public housing developments. The area authority will determine the eligibility of an individual or family to rent. The names of qualifying applicants are put on a waiting list until an applicable unit becomes available. Tenants generally pay 30 percent of their income, less program-eligible deductions toward rent. Contact the public housing administrator in your area for more information on the application process. Eligibility requirements include income limits and maximum rents.
  - **Project-based subsidy.** This refers to privately owned rental housing (for-profit or nonprofit) that is made available to people with low incomes. As with the public housing program, HUD administers federal aid to the private owner of the property. Tenants generally pay 30% of their income toward the rent. Some units are available specifically for families, those 62 and older, those who are chronically mentally ill, people with AIDS, and those with mobility impairments.
  - **Tax credit properties.** Landlords who are participating in a tax credit program must rent all or some of their units to low-income renters. The maximum rental amount is based on the established Area Median Income (AMI) for the area.

## Menu

1	Are You Financially Ready to Rent?
2	The Ins & Outs of Credit
3	How to Find the Right Place
4	Handling the Application Process
5	Understanding the Lease Agreement
6	Getting Back Your Security Deposit
7	Life as a Renter: Rights & Responsibilities
8	Housekeeping, Maintenance & Repairs
9	The Right Way to Terminate the Lease



HUD develops the Fiscal Year Median Family Income for all areas of the county, including Virginia. You can find current median incomes for various locations on HUD's website

- Housing Choice Voucher Program (former called Section 8). A tenant-based subsidy program that provides approved applicants a rent subsidy voucher, enabling them to search for affordable housing. The voucher holder must find a landlord willing to lease to them and accept the voucher. Tenants generally pay 30% of their income toward rent. The program administrator pays the balance of the rent directly to the landlord.

▶ **Detached property.** The most common type of detached property is the single-family home. Although typically occupied by one family, some private homes are divided to include the primary residence (occupied by the owner) and a second space (occupied by the tenant). The secondary space is often known as an income suite. The rental unit includes the basics: bedroom, kitchen, bath and living areas. The unit can mirror a traditional apartment with walls or an efficiency/suite with no walls, or limited walls. While a single-family detached property may appeal to families with children, the income suite often appeals to individuals and couples.

▶ **Manufactured homes (also known as mobile homes).** A manufactured, or mobile home, is a transportable structure designed to be a dwelling unit, with connections to required utilities such as plumbing, heating, air conditioning and electrical. Some mobile homes are installed as a permanent dwelling, while others are not. There are specific laws for renting mobile homes. The Virginia Manufactured Home Lot Rental Act (MHLRA) establishes the rights and obligations of owners, landlords and tenants.

### Property Types

You have many options regarding rental property types. You must be sure to do your research and select the best option for you. Some may include properties that are part of a homeowners association or condominium. These property types have additional restrictions that you must be aware of before selecting them.

## Menu

1 Are You Financially Ready to Rent?

2 The Ins & Outs of Credit

3 How to Find the Right Place

4 Handling the Application Process

5 Understanding the Lease Agreement

6 Getting Back Your Security Deposit

7 Life as a Renter: Rights & Responsibilities

8 Housekeeping, Maintenance & Repairs

9 The Right Way to Terminate the Lease

# Homeowner Association/ Condominium Renting

Homeowner association (HOA)/condominium (condo) rentals are dwelling units that the owners have vacated and are now renting out. Beware! Renting a dwelling that is part of a homeowner or condominium association is not like renting a typical apartment. There are strict rules and regulations that govern what can and cannot be done on the property. Although you're leasing directly with the owner of the property, the property association or board of directors still expects you, the tenant, to adhere to all rules. HOA/condo associations hold recurring meetings with individual property owners to discuss and make decisions regarding the property. Many associations will allow tenants to attend as observers only, but will not grant you voting rights.

The owner you rent from is still required to pay applicable association fees in their absence. If unpaid, the consequences can affect the renter. HOA/condo agreements often permit the association to terminate certain rights and privileges. The association is only required to communicate with the owner of record and has no obligation to inform the tenant of unpaid fees and subsequent consequences. Without notice, the tenant is left unprotected. For example, use of the community pool, fitness center and clubhouse can be terminated. The right to an assigned parking space may also be terminated, leaving the tenant's vehicle(s) subject to towing. The tenant may be caught off guard, only becoming aware of the situation when they are prohibited from using amenities or their vehicle has been towed.

It's important to understand the rules and regulations associated with these property types prior to signing a lease agreement. It is imperative to protect your interests.

## Menu

- 1 Are You Financially Ready to Rent?
- 2 The Ins & Outs of Credit
- 3 How to Find the Right Place
- 4 Handling the Application Process
- 5 Understanding the Lease Agreement
- 6 Getting Back Your Security Deposit
- 7 Life as a Renter: Rights & Responsibilities
- 8 Housekeeping, Maintenance & Repairs
- 9 The Right Way to Terminate the Lease

## Special Military Provisions

The Servicemembers Civil Relief Act (SCRA) provides some rental protection to active duty members of the armed forces, the Virginia National Guard and Reservists. It's important to be familiar with federal laws that govern apartment renting. Contact your installation's housing department, financial educator or JAG representative for specific questions and concerns.

While the SCRA provides rental protection to active duty military, the Disabilities Act and Fair Housing Act ensure people with disabilities are also provided rental protections. Learn more in the next section.



## People with Disabilities

Do you or someone in your household have a physical and/or sensory disability? The Americans with Disabilities Act (ADA) and the federal Fair Housing Act provide rules and guidance that address parking spaces, modifications and discrimination. Know your rights before beginning your search. Although Fair Housing laws require the landlord to permit modification, the cost of modifications can be expensive. It's usually the responsibility of the tenant to pay up front for any modifications needed to make a property accessible. In addition, the tenant may be responsible for restoring the property to its original unmodified condition after ending the lease. Keep in mind that modifications are often easier said than done.

Looking for a dwelling that already meets most, if not all, the accessibility needs of the household member can be a less expensive option. Several local and national search sites can help you find rentals with features such as wider doors, grab bars and entry ramps.

For example, VirginiaHousingSearch.com contains information on the accessibility features available in some properties. In addition, ask apartment locators for help and reach out to agencies in your area, such as the Centers for Independent Living (CIL).

## Menu

- 1 Are You Financially Ready to Rent?
- 2 The Ins & Outs of Credit
- 3 How to Find the Right Place
- 4 Handling the Application Process
- 5 Understanding the Lease Agreement
- 6 Getting Back Your Security Deposit
- 7 Life as a Renter: Rights & Responsibilities
- 8 Housekeeping, Maintenance & Repairs
- 9 The Right Way to Terminate the Lease



## Renting Alternatives

Should you be unable to obtain permanent housing or find a suitable independent living unit to rent, various temporary housing and supportive services are available. Check with your local city or county office to learn more about: assisted living facilities, halfway homes, shelters, sober living facilities, transitional housing and HUD's Veterans Affairs Supportive Housing (HUD-VASH).

## Beware of Rental Scams

Don't be a victim of rental property scams. Scammers often advertise through online sites such as Craigslist to get people to give them money for properties that are not really available or simply don't exist. It's all an elaborate trick! However, it's possible to spot phony ads. Below is a list of red flags and suggestions renters should consider while searching for that right place and before giving any money.

- ▶ **Red flag!** Upfront Payments. Beware of individuals who ask for money before the potential renter has actually viewed the property, such as applications fees or security deposits.
- ▶ **Red flag!** Cash only Payments. Beware of individuals who ask for cash only and will not accept guaranteed funds such as a cashier check or money order. Potential renters should never wire funds or provide credit card or bank account information to unknown persons.
- ▶ **Red flag!** Properties that come up for sale and not for rent; a nonexisting address; or a business address rather than a residential property: Run an online search of the property

## Menu

- 1 Are You Financially Ready to Rent?
- 2 The Ins & Outs of Credit
- 3 How to Find the Right Place
- 4 Handling the Application Process
- 5 Understanding the Lease Agreement
- 6 Getting Back Your Security Deposit
- 7 Life as a Renter: Rights & Responsibilities
- 8 Housekeeping, Maintenance & Repairs
- 9 The Right Way to Terminate the Lease

address, the supposed landlord’s name and any other contact information, i.e. email address and telephone number. Be especially cautious when no or limited contact information is provided.

- ▶ **Red flag!** Shows up in unrelated areas. Check and see if the advertisement pops up in another unrelated ad by cut, copying, and pasting a section of the advertisement into a search engine like Google. Scammers often copy real ads and may lower the price to deceive prospective renters.
- ▶ **Red flag!** Priced below the rental market. If the rental unit is priced extremely low and seems to be a great deal, ask yourself, “Is this too good to be true?” Take a moment to research comparable rents in the same neighborhood. This will help you understand what the average rent is and if the low-priced unit you found matches up. Everyone wants a good deal, but is it really a good deal or a scam?

### Suspect Fraud?

If you suspects fraud or were a victim of rental fraud:

- ▶ Report the incident to local law enforcement
- ▶ File a complaint with the Federal Trade Commission (FTC) — [ftc.gov](https://ftc.gov)
- ▶ Contact your local Virginia Legal Aid Society at [vlas.org](https://vlas.org) or the Legal Aid Justice Center at [justice4all.org](https://justice4all.org)
- ▶ Report the scam to the State Attorney General’s office — [oag.state.va.us](https://oag.state.va.us)
- ▶ Contact the website, newspaper or other sources of the ad immediately!



**Test Your Knowledge.** Take the quiz for this chapter and get a certificate of completion! You’ll be asked to create a user login, if you haven’t already: <https://VirginiaHousinglearningcenter.mkscloud.com>

## Menu

- 1 Are You Financially Ready to Rent?
- 2 The Ins & Outs of Credit
- 3 How to Find the Right Place
- 4 Handling the Application Process
- 5 Understanding the Lease Agreement
- 6 Getting Back Your Security Deposit
- 7 Life as a Renter: Rights & Responsibilities
- 8 Housekeeping, Maintenance & Repairs
- 9 The Right Way to Terminate the Lease



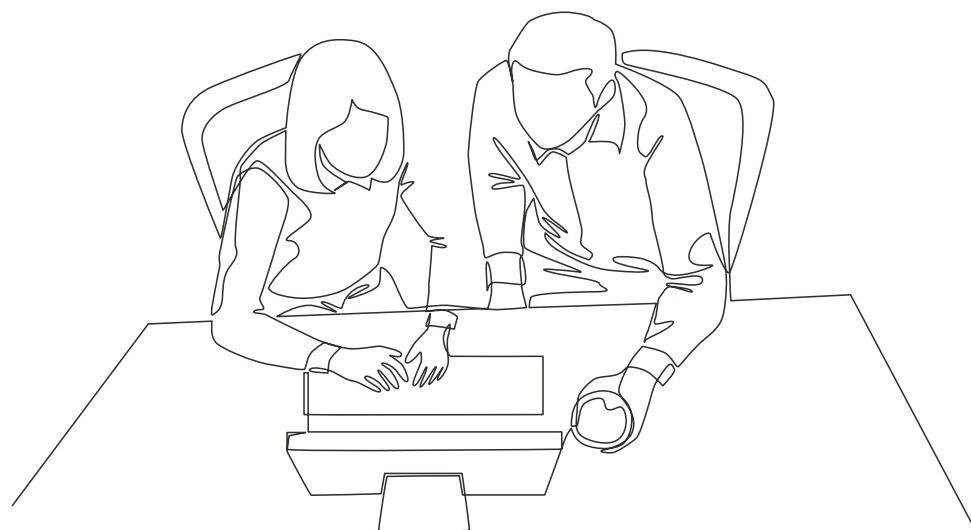

# Chapter 4

## Handling the Application Process

It took some time and effort, but you found the perfect rental you can't wait to call home. Now it's time to complete a rental application. Although there's no standard application, the documents involved are similar. Most landlords will ask applicants to disclose personal information that will enable them to check the prospective tenant's eligibility. It's important to be honest and answer all questions completely. This chapter details the process and identifies standard application questions.

## Menu

- 1 Are You Financially Ready to Rent?
- 2 The Ins & Outs of Credit
- 3 How to Find the Right Place
- 4 Handling the Application Process
- 5 Understanding the Lease Agreement
- 6 Getting Back Your Security Deposit
- 7 Life as a Renter: Rights & Responsibilities
- 8 Housekeeping, Maintenance & Repairs
- 9 The Right Way to Terminate the Lease

# Private Owner vs. Property Management Company

A residential landlord is defined as an owner (Private Owner) of one or more dwellings. In the case of multiple dwellings, the units may be clustered together or located in various areas. A landlord is also defined as the agent (Property Management Company) for the private owner. Keep in mind an owner could be a single person or a type of partnership, company or government agency.

The private owner can choose to act as the landlord or enter into an agreement with a designated representative, typically a property management company, to act on their behalf. The duties of the management company often include:

- ▶ The application process (discussed in this chapter).
- ▶ Executing the lease.
- ▶ Collecting fees, deposit and rent.
- ▶ Handling tenant concerns.
- ▶ Resolving maintenance issues.
- ▶ Handling delinquency notices and court procedures.
- ▶ Unit turnover.

## Private Owners and Property Management Companies

All private owners and property management companies are not created equally. That means there's no absolute answer when asked whether it is better to rent from a private owner or a property management company. However, here are a few factors to consider:

- ▶ Length of lease. A private landlord may be more flexible in negotiating the terms of your lease agreement. However, the ultimate decision belongs to the owner. Management companies are typically restricted to established lease terms, and often cannot grant waivers. The private landlord, however, could agree to a month-to-month, six-month, yearly, or any other term length. Private landlords may also negotiate application fees, the security deposit, rent amount and other lease terms.



## Menu

- 1 Are You Financially Ready to Rent?
- 2 The Ins & Outs of Credit
- 3 How to Find the Right Place
- 4 Handling the Application Process
- 5 Understanding the Lease Agreement
- 6 Getting Back Your Security Deposit
- 7 Life as a Renter: Rights & Responsibilities
- 8 Housekeeping, Maintenance & Repairs
- 9 The Right Way to Terminate the Lease

- ▶ **Background check.** More than likely, a management company will conduct a full screening. One of their primary responsibilities is to ensure the dwelling or development is occupied by tenants who will obey all rules and regulations. Background checks help with this decision. Private landlords often don't have the resources, or don't wish to invest the funds, for conducting a full screening. Because of this, applicants with credit issues and other issues may have a better chance to rent from a private landlord.
- ▶ **Knowledge of the laws.** The Virginia Residential Landlord and Tenant Act (VRLTA) sets mandates for the owners of multiple rental properties and their agents. Thus, property management companies likely have a good knowledge of the law. Some (eligible) private landlords may have opted out from following the VRLTA, so they may not have complete knowledge of the Act. However, opt-out landlords must be familiar with the Security Deposit, Sign Lease Agreement and Disclosure laws.
- ▶ **Concerns and complaints.** The timeliness in which concerns and complaints are addressed is important to all renters. This factor could vary with private landlords, as well as with management companies. Some private landlords who reside locally may be easy to reach and able to respond quickly. Absentee landlords (those who reside out of the area) may not be readily available. They may also have the added challenge of locating and hiring (when necessary) people to assist.
- ▶ **Management Companies**  
On the other hand, management companies keep normal business hours and typically have a contact number for emergency situations. They also typically have administrative and maintenance staff available to handle concerns and complaints.

<h1>Menu</h1>	
<b>1</b>	Are You Financially Ready to Rent?
<b>2</b>	The Ins & Outs of Credit
<b>3</b>	How to Find the Right Place
<b>4</b>	Handling the Application Process
<b>5</b>	Understanding the Lease Agreement
<b>6</b>	Getting Back Your Security Deposit
<b>7</b>	Life as a Renter: Rights & Responsibilities
<b>8</b>	Housekeeping, Maintenance & Repairs
<b>9</b>	The Right Way to Terminate the Lease

# Landlord's Objective: What Are They Looking For?

Simply put, landlords want a “good” tenant — someone who will pay the rent on time, maintain the property and follow the terms of the lease agreement. They also look for sufficient income to pay the rent and other financial obligations.

Landlords don't look favorably on applicants who owe past due rent and other monies to a previous landlord. They also don't want to rent to an applicant with a history of property neglect or damages.

To assess the desirability of a prospective tenant, landlords will often conduct a background check that may include a former landlord check, income check, credit check and a criminal record history check.

Before they can review your income and perform a background check, they must have a completed application.

## Obtaining the Application

The first step to completing an application is to contact the landlord or their agent to get an application form. Some landlords may require applicants to complete a written form. Others may use an electronic version of the application that allows prospective tenants to fill it out and submit it online.



## Menu

- 1 Are You Financially Ready to Rent?
- 2 The Ins & Outs of Credit
- 3 How to Find the Right Place
- 4 Handling the Application Process
- 5 Understanding the Lease Agreement
- 6 Getting Back Your Security Deposit
- 7 Life as a Renter: Rights & Responsibilities
- 8 Housekeeping, Maintenance & Repairs
- 9 The Right Way to Terminate the Lease

# Completing the Application

Before completing the application, it's important to read the instructions carefully and follow them exactly. For written applications, be sure to write legibly. An application that's hard to read could hurt your chance of renting the home you desire. Whether completing a paper or electronic application, you should:

- ▶ Answer all questions completely, accurately and honestly. Never lie!
- ▶ Take your time and never leave applicable questions unanswered.
- ▶ Don't skip over questions or leave out information just because you don't have it readily on hand. This will only cause processing delays.

## Application Components

Here are a few items applicants are often asked to provide, and a brief explanation as to why landlords require it.

- ▶ **Name (First, Middle and Last).** The full names of all applicant(s) are necessary to initiate a background search. Don't forget to include any suffix, such as Jr. or Sr. Some applications may ask for any former names used as well, such as a maiden name.
- ▶ **Social Security number.** This is also needed to run a background check. The nine-digit Social Security number (SSN) assigned to an individual by the Social Security Administration is a "matchless" personal identifier. Therefore, landlords require this information to confirm the applicant's identity. You may be asked to show your Social Security card and/or provide a copy of it.
- ▶ **Proof of identification.** A photo ID, such as a driver's license or military or government ID, is often required to verify an applicant's identity. Because identity theft is an ongoing concern, a photo ID is preferred, and often mandatory.
- ▶ **Date of birth.** This information is used to verify an applicant's age. Minors under the age of 18 aren't permitted to enter into a rental lease agreement, so landlords need to ensure that the prospective tenant is of legal age.

## Menu

- 1 Are You Financially Ready to Rent?
- 2 The Ins & Outs of Credit
- 3 How to Find the Right Place
- 4 Handling the Application Process
- 5 Understanding the Lease Agreement
- 6 Getting Back Your Security Deposit
- 7 Life as a Renter: Rights & Responsibilities
- 8 Housekeeping, Maintenance & Repairs
- 9 The Right Way to Terminate the Lease



- ▶ **Other occupants.** The applicant will need to list all household members who intend to occupy the dwelling. This includes other adults and minors. Often the date of birth and relationship to the applicant are also needed.



*Local occupancy restrictions may prohibit a family size of five from occupying a two-bedroom dwelling. In addition, rental assistance programs will assess all household members when calculating the tenants' rental/subsidy payment.*

- ▶ **Current address.** No matter what your living arrangements are, the landlord will request the address of your current residence. Often landlords contact the applicant's current landlord to determine if the applicant is on time with their rent payment and any other applicable fees. If not, landlords can ask the current status of the tenant's lease. For example, is there an eviction pending? Other inquiries may include the tenant's overall history, including following rules and regulations, history of property damage and history of late payments.
- ▶ **Previous address.** A landlord reference often includes an inquiry of the applicant's previous residency. The applicant's past rental history is important information. The inquiry may include whether or not rent was paid on time and whether the former tenant vacated with monies owed. Landlords will make the assumption that if the applicant was on time in paying the former landlord and conducted themselves within the terms of the agreement, they will continue to do so. The opposite is also true. A history of delinquency, poor conduct or excessive maintenance and damages issues will reflect negatively.
- ▶ **Telephone number.** While the application is being processed, additional information or clarification may be needed. Having a contact number is often the fastest way to get in touch with the applicant and avoid processing delays.

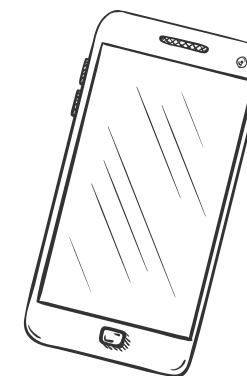

## Menu

- 1 Are You Financially Ready to Rent?
- 2 The Ins & Outs of Credit
- 3 How to Find the Right Place
- 4 Handling the Application Process
- 5 Understanding the Lease Agreement
- 6 Getting Back Your Security Deposit
- 7 Life as a Renter: Rights & Responsibilities
- 8 Housekeeping, Maintenance & Repairs
- 9 The Right Way to Terminate the Lease

- ▶ **Email address.** Email can be used as an alternative way to contact the applicant. Providing an email address allows the applicant or the landlord to receive required documents as an email attachment.
- ▶ **Income verification.** Can you afford to pay the rent each month? Do you have sufficient income? Employment and other sources of income are verified and calculated to answer these questions. You may be asked to provide documented proof of income, such as pay stubs, bank statements, etc. In addition, some landlords may request that applicants sign a third-party release of income form. The form authorizes employers, financial institutions and others to provide the landlord with verification of the applicant’s income.
- ▶ **Vehicle information.** It’s not uncommon for some apartment dwellings to have designated parking spaces or areas for authorized residents. This is why requested vehicle information often includes license plate number, make, model and vehicle color.
- ▶ **Pet information.** Rental properties that permit pets will request detailed information regarding the applicant’s pet. This may include the pet’s size and breed. A pet deposit or fee may be required as well.

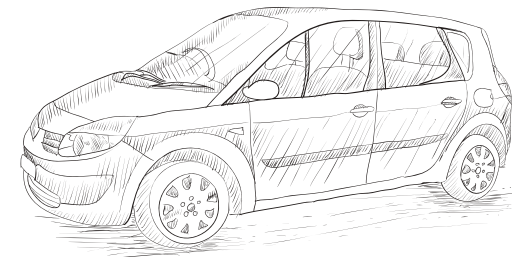

## Signing the Application and Other Related Documents

By signing the application and any related documents, you are confirming the accuracy of the information you’ve provided. It’s important to read any print that precedes the signature section to make sure you understand what you are authorizing the landlord to do with your information. A general “Release of Information” form is often signed, in addition to the application. The form will state that the applicant gives their permission to have information about them released to the landlord or the landlord’s agents.

## Menu

- 1 Are You Financially Ready to Rent?
- 2 The Ins & Outs of Credit
- 3 How to Find the Right Place
- 4 Handling the Application Process
- 5 Understanding the Lease Agreement
- 6 Getting Back Your Security Deposit
- 7 Life as a Renter: Rights & Responsibilities
- 8 Housekeeping, Maintenance & Repairs
- 9 The Right Way to Terminate the Lease

## Submitting the Application

Once you've completed the application and attached any required documents, it's time to submit your application. This is when landlords may require an application fee (discussed in the next section). Before you submit, take time to look over the application. Make sure to ask the landlord or their agent for clarification regarding any questions you may have. Again, never skip questions.

## The Application Fee

This fee generally covers any costs associated with processing your application. This may include what the landlord is charged to obtain a credit history and criminal record history report. The application fee cannot exceed \$50 per applicant for property regulated by the Virginia Residential Landlord and Tenant Act (VRLTA). Public housing or other housing regulated by the U.S. Department of Housing and Urban Development (HUD) cannot exceed \$32.

If the application fee seems unreasonably high, you have the right to ask for an explanation of how the fee monies are spent. Generally the application fee is not refundable.

## The Verification Process

It could take a few days for the landlord to process your application. Getting a credit history or criminal record report is relatively simple. However, getting third-party verifications, such as the landlord reference and income verifications, could take longer. Ask the landlord for a time frame — approximately how long should it take for a decision to be made? Get clarification — should you expect a telephone response, email notification or should you check back?

During the processing period, the landlord may call your current and/or previous landlord and telephone the employer listed. The first step however, is calculating whether or not your income is sufficient to pay the required rent. This means a look at your debt obligation as well. An obligation is any financial responsibility, not just debt that appears on the credit report.

## Menu

- 1 Are You Financially Ready to Rent?
- 2 The Ins & Outs of Credit
- 3 How to Find the Right Place
- 4 Handling the Application Process
- 5 Understanding the Lease Agreement
- 6 Getting Back Your Security Deposit
- 7 Life as a Renter: Rights & Responsibilities
- 8 Housekeeping, Maintenance & Repairs
- 9 The Right Way to Terminate the Lease

# Menu

- 1 Are You Financially Ready to Rent?
- 2 The Ins & Outs of Credit
- 3 How to Find the Right Place
- 4 Handling the Application Process
- 5 Understanding the Lease Agreement
- 6 Getting Back Your Security Deposit
- 7 Life as a Renter: Rights & Responsibilities
- 8 Housekeeping, Maintenance & Repairs
- 9 The Right Way to Terminate the Lease

Remember, not all creditors report to the credit reporting agencies. For example, some individuals may be required to pay child support. This debt would only appear on the credit report if it were delinquent. In addition, some landlords may ask to see your checking or savings information.

This verification process is conducted for all parties who sign the application/lease and will be responsible for the rent and property.

## Reasons for Application Denial

If you aren't approved for the rental, you have the right to ask the landlord why. Listed below are common reasons landlords deny applications.

- ▶ Insufficient Income: The length of employment may be too short, you might not have any credit history or you may have adverse credit with delinquencies, judgments, collections, bankruptcy or foreclosure.
- ▶ Criminal history (typically felonies).
- ▶ Negative rental history:
  - Not paying on time.
  - Delinquent amount still owed.
  - Evictions.
  - Substantial damages.
  - Improper conduct/behavior.
  - Other lease violations.
- ▶ Smoking.
- ▶ Pets.
- ▶ Dishonesty; making false or untrue statements.



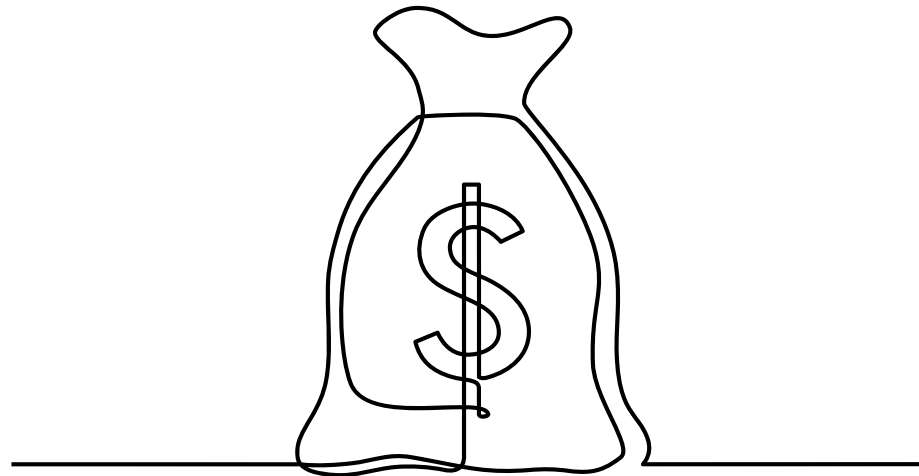

## Submitting the Security Deposit

In addition to the application fee, some landlords require a security deposit when submitting the application. If the landlord decides to deny your application to rent, the security deposit will be refunded within 20 days. If your payment was made by cash, cashier's check or money order, your payment will be refunded within 10 days. The security deposit will be refunded within 20 days if the applicant decides not to rent. Reasonable attorney's fees and the amount wrongfully withheld can be recovered if the landlord fails to refund the security deposit.



**Test Your Knowledge.** Take the quiz for this chapter and get a certificate of completion! You'll be asked to create a user login, if you haven't already: <https://VirginiaHousinglearningcenter.mkscloud.com>

## Menu

- 1 Are You Financially Ready to Rent?
- 2 The Ins & Outs of Credit
- 3 How to Find the Right Place
- 4 Handling the Application Process
- 5 Understanding the Lease Agreement
- 6 Getting Back Your Security Deposit
- 7 Life as a Renter: Rights & Responsibilities
- 8 Housekeeping, Maintenance & Repairs
- 9 The Right Way to Terminate the Lease



# Chapter 5

## Understanding the Lease Agreement

The rights and responsibilities of both the landlord and the tenant are spelled out in the lease agreement. The Virginia Residential Landlord and Tenant Act (VRLTA) covers most residential rental agreements, but not all. Some properties and landlords are exempt from the Act. If the lease was prepared in accordance with the VRLTA, it will be stated in the rental agreement.

Whether a rental lease agreement is covered by the Act or not, landlords are expected to comply with building and housing codes, make necessary repairs, ensure major systems and appliances are in working order, and ensure the dwelling and common areas are safe. Tenants are responsible for keeping the dwelling clean, paying their rent on time and quickly notifying the landlord about any concerns.

This chapter covers guidelines set by the VRLTA. It also explains the importance of reading and understanding the lease agreement, and where to find assistance if and when you need it. We'll also explain the types of lease agreements, the truth about common misunderstandings and how rent-to-own programs work.

### Menu

- 1 Are You Financially Ready to Rent?
- 2 The Ins & Outs of Credit
- 3 How to Find the Right Place
- 4 Handling the Application Process
- 5 Understanding the Lease Agreement
- 6 Getting Back Your Security Deposit
- 7 Life as a Renter: Rights & Responsibilities
- 8 Housekeeping, Maintenance & Repairs
- 9 The Right Way to Terminate the Lease

## What is the Lease Agreement?

The lease agreement, also known as the rental agreement, is a legally binding document that outlines the rights and responsibilities of both the landlord and the tenant. This includes those acting on behalf of the landlord, such as a property management company, maintenance staff and contractors. The agreement also includes guidelines for the guests of authorized tenants. A lease agreement can contain language that is not easily understood and favors the landlord. This is why it's so important to completely understand the agreement before you sign it.



## VRLTA Landlords and Opt-Out Landlords

Throughout Virginia, local and county governments set regulations for landlords who lease one or more properties within their jurisdiction. Often these rules are limited to building and housing codes. The Virginia Residential Landlord and Tenant Act (VRLTA) is much broader in that it requires certain properties and certain landlords to follow laws specifically outlined in the Act. Although not legally required to do so, some non-VRLTA landlords do follow the laws in full or in part.

VRLTA landlords, and opt-out landlords who follow the laws, must include a VRLTA Disclosure within their lease agreement. The disclosure acknowledges that the agreement was prepared in accordance with the VRLTA. All other leases are written at the discretion of the landlord. All lease agreements must be in writing.

- 1 Are You Financially Ready to Rent?
- 2 The Ins & Outs of Credit
- 3 How to Find the Right Place
- 4 Handling the Application Process
- 5 Understanding the Lease Agreement
- 6 Getting Back Your Security Deposit
- 7 Life as a Renter: Rights & Responsibilities
- 8 Housekeeping, Maintenance & Repairs
- 9 The Right Way to Terminate the Lease

# Before You Sign

First and foremost, read the lease agreement in its entirety. If possible, take the lease agreement home to read through before you sign. If you have questions about the lease, ask the landlord for clarification. If assistance is still needed, locate a Department of Housing and Urban Development (HUD) Housing Counseling Agency. HUD provides a list of HUD-approved housing counseling agencies on their website at [hud.gov](http://hud.gov). Search the site for an agency that provides rental counseling which includes reviewing lease agreements. Counseling provided by HUD-approved agencies is free.

You can also find free legal assistance from various sources throughout the state, including:

- ▶ [valegalaid.org/find-legal-help/directory](http://valegalaid.org/find-legal-help/directory)
- ▶ The Virginia Legal Aid Society at [vlas.org](http://vlas.org)
- ▶ Legal Services of Northern Virginia at [lsnv.org](http://lsnv.org)
- ▶ Central Virginia Legal Aid Society at [cvlas.org](http://cvlas.org)
- ▶ Southwest Virginia Legal Aid Society at [svlas.org](http://svlas.org)
- ▶ Legal Aid Justice Center at [justice4all.org](http://justice4all.org)



*Free assistance may also be provided by other legal professionals, such as Legal Aid. Check for available rental assistance in your area. In addition, the Judge Advocate General Corps (JAG) provides assistance to military service members.*

## Understand and Agree to Terms

While reviewing the lease, and before signing, check to see if you agree with and understand all of its components.

### Term

The length of the lease (term) and the renewal policy.

### Address

The address of the property (make sure it's the unit you agreed upon).

## Menu

- 1 Are You Financially Ready to Rent?
- 2 The Ins & Outs of Credit
- 3 How to Find the Right Place
- 4 Handling the Application Process
- 5 Understanding the Lease Agreement
- 6 Getting Back Your Security Deposit
- 7 Life as a Renter: Rights & Responsibilities
- 8 Housekeeping, Maintenance & Repairs
- 9 The Right Way to Terminate the Lease

### Rent Amount

The rent amount, security deposit or other costs paid in advance (or that you're expected to pay in the future). This may include utilities, trash removal, pet deposit and parking fees.

How and when the rent amount can increase.

### Rent Payment

Rent payment details: where to submit, the due date, late charge acceptable form of payment (i.e., cash, check, money order).

### Occupancy Rules

Occupancy provisions and the guest policy.

### Other Policies and Rules

Other policies, such as pet, smoking or damages provisions.

Who to contact with concerns or complaints.

The landlord's right to terminate the lease.

How to give proper notice when you decide it's time to vacate.



## Verbal Lease Agreements

In Virginia, verbal lease agreements are not legal. Effective July 1, 2019, landlords must offer written leases. If the landlord does not do that, the law will establish a lease that will specify the following: the lease term will be 12 months, a fair market rent will be paid in 12 equal monthly payments in the amount agreed upon, a reasonable late fee shall be paid if rent isn't paid by the fifth of each month, and the landlord may collect a security deposit no greater than two months' rent. During the walk-through, take pictures and document any areas of concern, especially pre-existing damage. Be sure to make the landlord and/or management company aware (in writing) of any damages. Always keep copies of this documentation for yourself.

## Menu

- 1 Are You Financially Ready to Rent?
- 2 The Ins & Outs of Credit
- 3 How to Find the Right Place
- 4 Handling the Application Process
- 5 Understanding the Lease Agreement
- 6 Getting Back Your Security Deposit
- 7 Life as a Renter: Rights & Responsibilities
- 8 Housekeeping, Maintenance & Repairs
- 9 The Right Way to Terminate the Lease

## Menu

- 1 Are You Financially Ready to Rent?
- 2 The Ins & Outs of Credit
- 3 How to Find the Right Place
- 4 Handling the Application Process
- 5 Understanding the Lease Agreement
- 6 Getting Back Your Security Deposit
- 7 Life as a Renter: Rights & Responsibilities
- 8 Housekeeping, Maintenance & Repairs
- 9 The Right Way to Terminate the Lease

## Month-to-Month Lease

The month-to-month lease ends at the end of each month and must be renewed monthly. This lease is good for someone who isn't sure how long they're going to be in the area or someone waiting for permanent housing elsewhere. Some disadvantages of the month-to-month lease include:

- ▶ The rent can increase monthly.
- ▶ The wording in the lease may change.
- ▶ The landlord may decide not to renew the lease.
- ▶ Rates may be significantly higher when leasing month-to-month as a way for the landlord to make the entire profit off the lease, no matter what the term is.

For example:

- 12 month lease at \$500/mo. (12 x \$500 = \$6,000)
- 9 month lease at \$667/mo. (9 x \$667 = \$6,003)
- 6 month lease at \$1,000/mo. (6 x \$1000 = \$6,000)

## Standard Terms of the Lease Agreement

The lease agreement outlines rules, regulations, rights and responsibilities, as well as policies and procedures. Common sections of a standardized lease agreement include:

- ▶ **Effective date.** The lease agreement must be signed by all applicants before occupying the dwelling. The date on which the lease is signed is considered the effective date. Signing the lease is often done days before the move-in date. That means the effective date and move-in date can be different. Remember, once you sign it, the lease becomes a legally binding agreement. You could lose all or part of your security deposit if you fail to take possession of the home.



# Menu

- 1 Are You Financially Ready to Rent?
- 2 The Ins & Outs of Credit
- 3 How to Find the Right Place
- 4 Handling the Application Process
- 5 Understanding the Lease Agreement
- 6 Getting Back Your Security Deposit
- 7 Life as a Renter: Rights & Responsibilities
- 8 Housekeeping, Maintenance & Repairs
- 9 The Right Way to Terminate the Lease

- ▶ **Parties.** All applicants responsible for the rent and for compliance to the terms of the agreement will be listed in this section. This includes the names of both spouses, co-tenants and co-signers. This section will also list the name of the landlord(s), partnership name and property management company, if applicable.
- ▶ **Terms.** The length of the lease will be indicated as a start date and an ending date. The property address may also be included in this section.
- ▶ **Rent.** The total amount of rent due from the start to ending date is typically indicated in this section, along with the initial rent payment amount, monthly recurring amounts and the final payment amount. All other amounts you're expected to pay (other than a security deposit) may be provided in this section as well. This section also provides important information regarding when and how payments are to be submitted. Paying in person, by mail or direct deposit into the landlord's designated account are a few payment options.

## Mailing Rent

If payment is mailed, the tenant assumes the risk that the payment may be lost in the mail and that they may be required to submit another payment in the event that the first payment does not reach the landlord. The landlord shall consider rent received by mail as having been timely paid as long as it's postmarked by the due date. Checks and money orders shall be made payable to the landlord unless the tenant is otherwise notified in writing. Each check or money order shall include the address of the premises.

Never mail cash!

- ▶ **Late fee.** The amount charged when a payment is received after the allowed grace period (specified in the lease). Normally, this fee is a percentage of the rent payment, but it may also be a set amount. Paying rent and other charges late can be costly. Rent is typically due on the first of each month, with grace periods of five days. The lease agreement may specify that any amount not received by 5 p.m. on the fourth day after the due date will be assessed a late fee of 10%. So, if the late fee is 10% of the unpaid amount, and the unpaid amount is \$600, the tenant would be responsible for an additional \$60 ( $\$600 \times 10\% = \$60$ ).

# Menu

- 1 Are You Financially Ready to Rent?
- 2 The Ins & Outs of Credit
- 3 How to Find the Right Place
- 4 Handling the Application Process
- 5 Understanding the Lease Agreement
- 6 Getting Back Your Security Deposit
- 7 Life as a Renter: Rights & Responsibilities
- 8 Housekeeping, Maintenance & Repairs
- 9 The Right Way to Terminate the Lease

- ▶ **Return check fee.** Also referred to as “insufficient funds” and “dishonored checks,” this is a fee charged when the bank does not honor the check payment submitted due to insufficient funds. When landlords incur these fees, they pass that cost on to the tenant. For example, the tenant would be assessed an additional \$50 for each returned check, plus any applicable late fee and other recoverable amounts. Recoverable amounts could include legal and court costs. In addition, the landlord may require that future rent payments be made by guaranteed funds such as cash, money order, cashier’s check, certified check or automatic electronic payment.
- ▶ **Security deposit.** This is one of the most important parts of the lease agreement. The amount of security deposit paid upfront is found here. In addition, the lease often provides details regarding:
  - **Tenant’s breach of lease.** The landlord may deduct from the security deposit the amount of any damages to the rental unit. In addition, tenants are not entitled to have the security deposit applied to unpaid rent or late fees during the term of this lease, or to have the last month’s rent deducted from the deposit.
  - **Termination of tenancy.** The security deposit will be used to pay for all reasonable repairs and cleaning costs caused by the tenant. It’s important that you leave the premises in good repair and condition (reasonable wear and tear excepted), and return all keys.
  - **Processing the security deposit.** If the tenant complies with all terms and conditions of the lease, the landlord will return the security deposit, along with any accrued interest, if applicable. The landlord will provide tenants an itemized list of security deposit deductions (if any) within 45 days, or as required by law.
  - **Excess damages.** If damages exceed the amount of the deposit and require the services of a third-party contractor, the landlord must give written notice to the tenant advising them of this. VRLTA-covered properties are required to

provide this notice within 45 days. With this notice the landlord has an additional 15 days to provide an itemization of the damages and the cost of repair(s).

- **Forwarding address.** Tenants are required to provide the landlord written notice of their forwarding address on or before termination of the tenancy. The landlord will mail any refundable amount, plus the required documentation, to the forwarding address provided. If no forwarding address is provided, the landlord will use the address of the leased premises. In this case, the tenant should make sure that the post office has a forwarding address on file.
- **Co-tenants.** The landlord is only required to write one check payable to all authorized tenants (more on co-tenants later in this chapter).
- ▶ **Authorized minors and other occupants.** This part of the lease agreement often limits occupancy to the household members listed on the application. The name and relationship to the applicant will be recorded, and the lease typically excludes anyone else from occupying the dwelling.
- ▶ **Residential dwelling only.** The lease agreement often restricts use of the premises for any purpose other than as a residential dwelling. Restricted uses often include:
  - Unlawful activities.
  - Unreasonable interference with the rights, comforts or conveniences of neighbors.
  - Unreasonable interference in a manner that will cause any type of damage.
  - Hosting parties or gatherings in excess of the number of people and times permitted.
  - Sub-leasing (described later in this chapter).

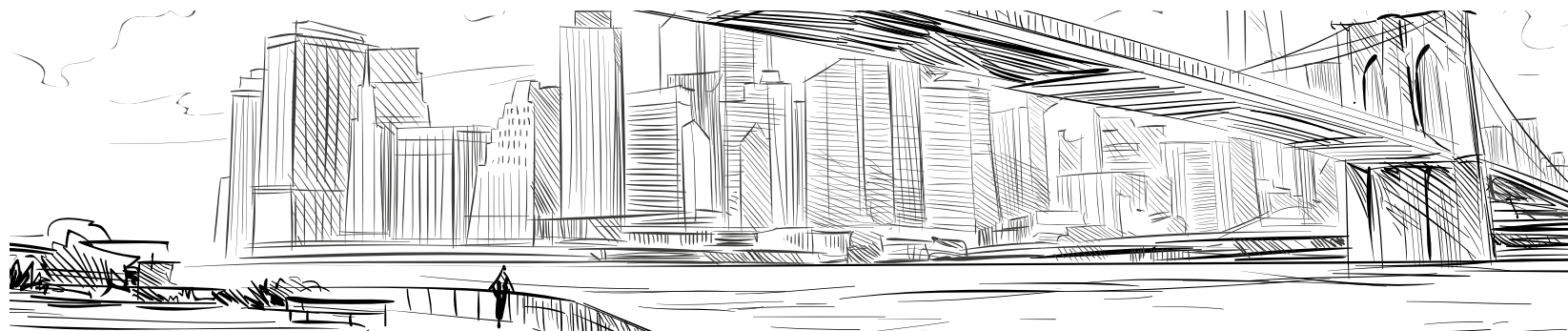

## Menu

- 1 Are You Financially Ready to Rent?
- 2 The Ins & Outs of Credit
- 3 How to Find the Right Place
- 4 Handling the Application Process
- 5 Understanding the Lease Agreement
- 6 Getting Back Your Security Deposit
- 7 Life as a Renter: Rights & Responsibilities
- 8 Housekeeping, Maintenance & Repairs
- 9 The Right Way to Terminate the Lease

# Menu

- 1 Are You Financially Ready to Rent?
- 2 The Ins & Outs of Credit
- 3 How to Find the Right Place
- 4 Handling the Application Process
- 5 Understanding the Lease Agreement
- 6 Getting Back Your Security Deposit
- 7 Life as a Renter: Rights & Responsibilities
- 8 Housekeeping, Maintenance & Repairs
- 9 The Right Way to Terminate the Lease

► **Move-in and move-out.** The condition of the property prior to move-in and once the dwelling has been vacated is typically covered in this section of the lease agreement. Landlords are expected to deliver a residential unit in a safe, clean and habitable condition. This includes a dwelling free of rodents, pests and visible mold. In addition, the property should have a smoke detector(s), utilities and appliances in working condition.



*Most leases will include sections that list the dwelling appliances, other properties, and utilities that are the landlord's responsibility and which are the tenant's responsibility. Reasonable efforts to prevent the accumulation of moisture and growth of mold are the responsibility of both.*

## Move-In/Move-Out Conditions

The condition of the property at move-in is extremely important. Some landlords will provide a "Move-in/Move-out Condition" report. If no report is provided, you should take the initiative to inspect the property yourself and prepare your own condition report. Take pictures! Some cameras and other video devices have time/date stamp technology. If applicable, make sure this feature is turned on. Submit that report to the landlord, but keep a copy for your records. Remember, tenants are expected to maintain the dwelling in good condition, less reasonable wear and tear.

At the time of move-out, the ability to prove a condition was pre-existing when you moved in will be valuable. You have the right to request a move-out inspection and be present during the inspection. Again, take pictures! This request should be made at least two weeks in advance of your moving out date.

## Termination of Lease and Inspections

► **Termination of lease.** Either party can terminate the lease when something in the lease agreement is not complied with. The termination should be done in writing.

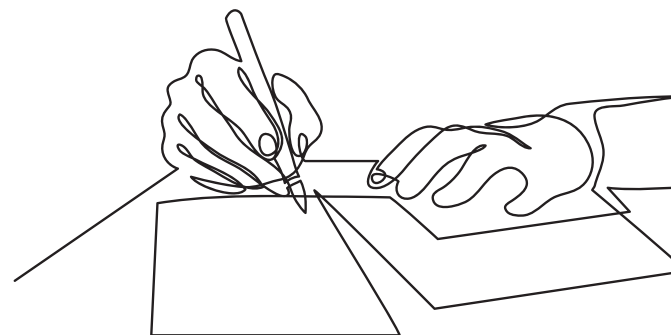



# Menu

- 1 Are You Financially Ready to Rent?
- 2 The Ins & Outs of Credit
- 3 How to Find the Right Place
- 4 Handling the Application Process
- 5 Understanding the Lease Agreement
- 6 Getting Back Your Security Deposit
- 7 Life as a Renter: Rights & Responsibilities
- 8 Housekeeping, Maintenance & Repairs
- 9 The Right Way to Terminate the Lease

- ▶ **Inspections.** Landlords can inspect the property during the renter’s tenancy. At least 48 hours’ prior notice is customary. Most leases will have a detailed section regarding maintenance and damages. This usually will include:
  - Use of electrical, plumbing, heating, ventilating, air conditioning and other fixtures, and appliances.
  - Tenant’s responsibility for general maintenance. Apartment communities with on-site maintenance often:
    - ▶ Change filters.
    - ▶ Clean exterior/siding.
    - ▶ Replace screens and broken glass.
    - ▶ Unclog drains and other plumbing stoppages.
    - ▶ Exterminate for infestation of pest or rodents.
    - ▶ Provide sidewalk and driveway care.
    - ▶ Maintain grounds, including landscaping.

However, if you rent a single-family house, condo or townhouse, you may be required to handle all or some general maintenance and damage repair.

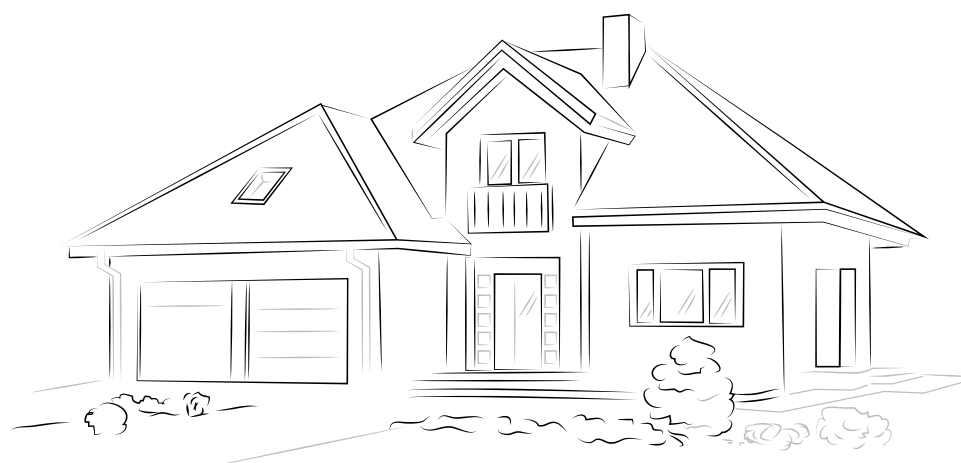



# Optional Lease Provision

Additional provisions that may or may not be part of a lease agreement include:

- ▶ **Early rent discount.** Some landlords may reward tenants with a rent discount for paying their rent before the due date. An example of this would be a provision that rent in the amount of \$600 will be reduced to \$550 when the payment is received prior to the due date (typically the first of each month). In this example, there is a \$50 incentive to pay before the first. Read this section thoroughly to clearly understand the provision.
- ▶ **Prepaid or advanced rent.** A tenant may offer, and a landlord may accept, prepaid rent. If a landlord accepts prepaid rent, they are to deposit the prepaid amount in an escrow account in a Virginia federally insured depository by the end of the fifth business day following receipt of the payment. The total amount remains in the account until such time as the prepaid rent becomes due. Unless the landlord has otherwise become entitled to receive any part of the prepaid rent, it may not be removed from the escrow account without the written consent of the tenant.
- ▶ **Renters insurance clause.** This clause either suggests or mandates that the tenant buy a renters insurance policy for the lease term. Renters insurance protects the renter's property and provides liability coverage for the renter. It may also reduce the landlord's liability.  
Where mandated, the tenant would agree to provide the landlord sufficient proof that a policy was purchased.
- ▶ **No-smoking clause.** Where applicable, some landlords will add a no-smoking clause to their lease agreement. This is most common in single-family houses and senior developments. Other properties may provide a designated smoking area.
- ▶ **Pet clause.** This clause indicates whether or not the landlord permits pets. If allowed, there may be restrictions such as the type, size and breed. In addition, if pets are allowed, a nonrefundable fee or deposit is often required. Except for qualified service animals, landlords reserve the right to prohibit pets.

## Menu

- 1 Are You Financially Ready to Rent?
- 2 The Ins & Outs of Credit
- 3 How to Find the Right Place
- 4 Handling the Application Process
- 5 Understanding the Lease Agreement
- 6 Getting Back Your Security Deposit
- 7 Life as a Renter: Rights & Responsibilities
- 8 Housekeeping, Maintenance & Repairs
- 9 The Right Way to Terminate the Lease

- ▶ **Prompt notification for repairs clause.** Landlords may add a separate clause that mandates the tenant’s responsibility to notify the landlord within a certain time frame if something breaks. It can be verbal or written notification. Addressing problems before they become larger and more costly problems is better for everyone.
- ▶ **Smoke detector clause.** This clause may clearly state that the tenant, all household members and their guests are responsible for reasonable care and maintenance of all smoke detectors, including interim testing. The tenant will notify the landlord promptly of any malfunctioning detectors. Most importantly, the occupants shall not do anything to render the detector inoperable, to include:
  - Tampering.
  - Removing working batteries.
  - Disconnecting the smoke detector.

## Addendum to Lease

An addendum to the lease is used to add, delete or modify any or all of the information of the original lease. The addendum can be requested by the landlord or the tenant.

A good example of an addendum is, if your lease agreement does not mention anything about pets, but you would like to have a pet. It would be beneficial for both parties to create an addendum indicating that pets are allowed and the tenant is responsible to clean up after the pet as well as for any property damage caused by the pet. The addendum cannot replace the original lease agreement, but it’s always a good idea to have an addendum referenced in the original lease.

## Menu

- 1 Are You Financially Ready to Rent?
- 2 The Ins & Outs of Credit
- 3 How to Find the Right Place
- 4 Handling the Application Process
- 5 Understanding the Lease Agreement
- 6 Getting Back Your Security Deposit
- 7 Life as a Renter: Rights & Responsibilities
- 8 Housekeeping, Maintenance & Repairs
- 9 The Right Way to Terminate the Lease

# Types of Rental Agreements

**Co-tenants.** Sometimes a lease agreement is entered into with one or several individuals. All parties who signed the agreement are considered co-tenants and are equally responsible for rent and all monies owed, the care and maintenance of the property and the lease provisions.

A separate agreement could be established between the co-tenants only. This document could outline the responsibilities of everyone. It may include how much each tenant is to pay toward the rent, which bedroom is occupied by whom, division of utilities, a cleaning schedule and other specifics.

In some college-area housing, co-tenants can sign individual leases with the landlord and only be responsible for their individual rent. In this scenario, one tenant would not be liable for any damages the other tenant does to their bedroom, although everyone is liable for damages done to common areas in the apartment.

**Co-signing.** Some applicants will face challenges getting application approval. These challenges may include having no established credit, insufficient credit and an inadequate employment history. These potential renters can turn to a friend or family member to assist by asking them to co-sign on the lease agreement. Co-signers take on the responsibility of paying rent and any other costs if the tenant fails to do so.

If the co-signer is creditworthy and shows sufficient income, some landlords may permit this type of agreement. Co-signers are subject to background checks like those done on the actual tenant. Co-signing is a big commitment. The tenant could receive application approval based on their co-signers. However, the co-signer is putting their trust in the tenant. No one wants to pay someone else's debt.

Parents often co-sign for their children to help them establish credit and a rental history. Paying rent on time and adhering to the lease terms will help with future rentals and eliminate the need for a co-signer next time. However, it's important to know that failure to pay the rent should not be taken lightly just because you have a co-signer on your lease agreement. The landlord will take action against you as well as the co-signer.

## Menu

- 1 Are You Financially Ready to Rent?
- 2 The Ins & Outs of Credit
- 3 How to Find the Right Place
- 4 Handling the Application Process
- 5 Understanding the Lease Agreement
- 6 Getting Back Your Security Deposit
- 7 Life as a Renter: Rights & Responsibilities
- 8 Housekeeping, Maintenance & Repairs
- 9 The Right Way to Terminate the Lease

**Sub-leasing.** Most landlords do not allow tenant(s) to sublease all, or even a portion, of the premises. (Remember the occupancy and guest provisions mentioned above.) Landlords who will permit this type of agreement often require you to get written permission from them. Landlords are never obligated in any way to grant permission. Some landlords require a sub-lessee to undergo credit/background checks, fill out an application and sign a new lease or addendum stating the sub-lessee is taking over the current tenant's lease.

In Virginia, the lessee is still liable to pay rent to the landlord, whether or not the sub-lessee pays their rent. That's why it's always highly recommended that you check the credit of all potential sub-lease tenants.

## As-is Lease Agreement

In addition to the lease agreement types described previously, there is also an As-is lease agreement. Under this agreement, the landlord does little to no interior maintenance, repair or replacement of damaged items, or yard maintenance. If an as-is lease is provided, read it carefully. As the name implies, you're renting the property exactly the way it is. The rent is typically reduced when the tenant is responsible for all maintenance and yard work.

## Common Misunderstandings

It is imperative to be clear about the rights and responsibilities for tenants and those for landlords. Here are a few common misunderstandings regarding the rights and responsibilities of both the landlord and the tenant.

### Arrest

The landlord can evict you immediately or have you arrested for not paying rent. After non-payment of rent, the landlord must provide the tenant with a letter of nonpayment. If the tenant has still not paid, then the landlord can proceed with terminating the lease and initiate the eviction process. *The landlord cannot have you arrested for nonpayment.*

## Menu

- 1 Are You Financially Ready to Rent?
- 2 The Ins & Outs of Credit
- 3 How to Find the Right Place
- 4 Handling the Application Process
- 5 Understanding the Lease Agreement
- 6 Getting Back Your Security Deposit
- 7 Life as a Renter: Rights & Responsibilities
- 8 Housekeeping, Maintenance & Repairs
- 9 The Right Way to Terminate the Lease

### Job Loss

Tenants can be evicted if they lose their job or become disabled. *Losing a job or becoming disabled is not a reason for eviction.* However, if the job loss or the disability causes the tenant to miss rent payments, the nonpayment of rent would be a cause to initiate eviction procedures.

### Insurance

The insurance the landlord has on the rental property will cover all of the tenant's personal belongings. The insurance that the landlord has on the property will only cover the landlord's property. *The coverage will not cover the tenant's personal property. Renters insurance is what covers the tenant's personal property.*

### HOA/Condo Fees

When renting a condo or a townhouse, it is the responsibility of the tenant to pay the HOA/condo fees. *In most cases, the landlord is responsible for the HOA/condo fees.* However, tenants should make sure that they are aware of the HOA/condo provisions. The landlord could add a clause in the lease agreement that makes paying the HOA or condo fee the responsibility of the tenant.

### Inspections

The landlord can enter the dwelling to inspect the property whenever they like and as often as they like. *All landlords must provide the tenant advance notice (except in the case of an emergency) before entering into a tenant's dwelling.*

### Repairs

The tenant can withhold rent until the landlord makes repairs. *Tenants can never withhold rent.* You must follow the Tenant's Assertion procedures of the courts.

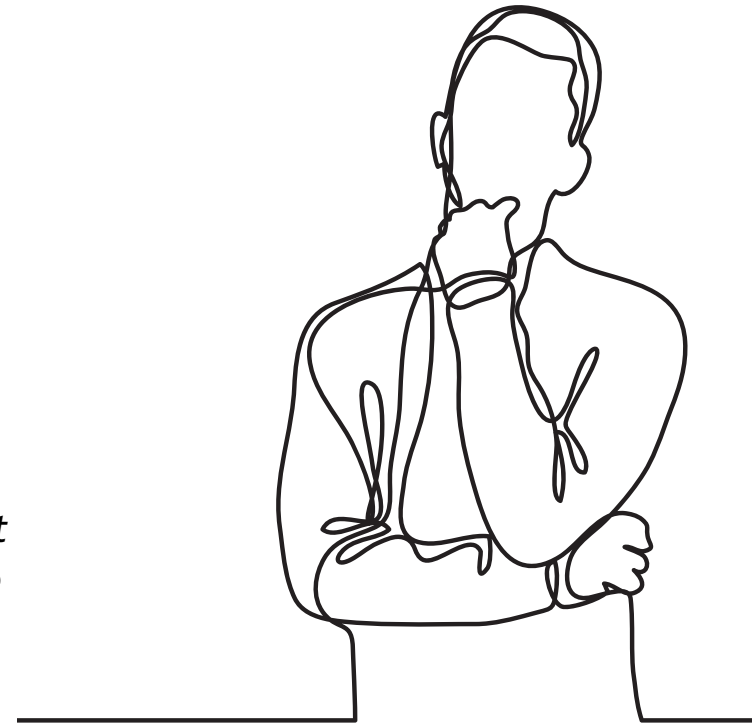

Menu	
1	Are You Financially Ready to Rent?
2	The Ins & Outs of Credit
3	How to Find the Right Place
4	Handling the Application Process
5	Understanding the Lease Agreement
6	Getting Back Your Security Deposit
7	Life as a Renter: Rights & Responsibilities
8	Housekeeping, Maintenance & Repairs
9	The Right Way to Terminate the Lease



# Rent-to-Purchase Programs

Throughout Virginia, the terms “rent-to-own,” “rent-purchase,” and “lease-purchase” are often used interchangeably. What some areas or programs define as their “Rent-to-Own” program, another area or program will define as their “Lease Purchase” program. Both have many common characteristics. The main one is that they provide the renter with an opportunity to purchase the leased property at some point in time.

This may be a great option for tenants who would like to own, but currently face challenges getting a traditional home loan. Traditionally, homebuyers need to acquire financing (a mortgage loan) in order to buy a home. Lenders require that borrowers qualify for a home loan, including providing proof of:

- ▶ Sufficient income.
- ▶ At least two years of steady employment or other income.
- ▶ A good credit history.
- ▶ Adequate savings.

## Common Rent-to-Purchase Programs

Rent-purchase programs allow the tenant to rent the home they wish to buy, while giving them time to overcome financial challenges. In other words, the tenant may be working toward improving their credit and making regular deposits into a saving account.

Rent-purchase programs also feature an escrow account, in which a portion of the tenant’s rent is set aside for the eventual purchase of the property. The set-aside is used toward the down payment and/or purchase of the property. This chart shows the similarities and differences of two common rent-purchase programs. To avoid confusion, we will simply title the purchase programs as Option 1 and Option 2.

## Menu

- 1 Are You Financially Ready to Rent?
- 2 The Ins & Outs of Credit
- 3 How to Find the Right Place
- 4 Handling the Application Process
- 5 Understanding the Lease Agreement
- 6 Getting Back Your Security Deposit
- 7 Life as a Renter: Rights & Responsibilities
- 8 Housekeeping, Maintenance & Repairs
- 9 The Right Way to Terminate the Lease



# Menu

- 1 Are You Financially Ready to Rent?
- 2 The Ins & Outs of Credit
- 3 How to Find the Right Place
- 4 Handling the Application Process
- 5 Understanding the Lease Agreement
- 6 Getting Back Your Security Deposit
- 7 Life as a Renter: Rights & Responsibilities
- 8 Housekeeping, Maintenance & Repairs
- 9 The Right Way to Terminate the Lease

	Option 1	Option 2
<b>Term (Length of Agreement)</b>	12 – 36 months	15, 20 or 30 years
<b>Set-aside Payment</b>	Applied toward down payment	Applied toward purchase price
<b>Monthly Payment Required</b>	Yes	Yes
<b>Financing Needed</b>	Yes Required to finance the remaining balance	No Additional funding is not required
<b>Transfer of Property</b>	Tenant required to purchase property prior to end of term	Automatically transfers at end of the term

## Option 1

Typically, the length of the agreement ranges from 12 to 36 months. Landlords have the right to set the term. The renter (buyer) and the landlord (seller) agree on the eventual purchase price. The monthly rent payment is calculated based on the purchase price, with part of the payment going toward rent and part going to the eventual purchase of the property. The set-aside amount (often referred to as an escrow account) can be applied toward any down payment or closing cost (see below).

The remaining balance to buy the property will be financed by the tenant. Prior to the expiration of the lease, the tenant will need to purchase the property. It is recommended the tenant begin the loan application process at least six months in advance. Ownership will be transferred from the landlord (seller) to the tenant (buyer) as long as the tenant buys before the expiration of the lease. If not, the tenant could lose all escrow funds and the chance to buy.

### Example / Option 1:

Tenant agrees to buy the property within three years (36 months).  
 The total monthly payment is \$900 (\$750 rent and \$150 escrowed).  
 $\$150 \times 36 \text{ months} = \$5,400$  (toward down payment or closing costs).

# Menu

- 1 Are You Financially Ready to Rent?
- 2 The Ins & Outs of Credit
- 3 How to Find the Right Place
- 4 Handling the Application Process
- 5 Understanding the Lease Agreement
- 6 Getting Back Your Security Deposit
- 7 Life as a Renter: Rights & Responsibilities
- 8 Housekeeping, Maintenance & Repairs
- 9 The Right Way to Terminate the Lease

	Option 1	Option 2
<b>Term (Length of Agreement)</b>	12 – 36 months	15, 20 or 30 years
<b>Set-aside Payment</b>	Applied toward down payment	Applied toward purchase price
<b>Monthly Payment Required</b>	Yes	Yes
<b>Financing Needed</b>	Yes Required to finance the remaining balance	No Additional funding is not required
<b>Transfer of Property</b>	Tenant required to purchase property prior to end of term	Automatically transfers at end of the term

## Option 2

As in Option 1, the owner (seller) and renter (buyer) agree up front on the terms of the transaction. This will include the purchase price, monthly payment, escrow account and the start and end date of the contract. The lease term may be for 15, 20 or 30 years. In this scenario, a larger portion of the rent payment goes to the purchase price of the home. In actuality, the tenant is making payments directly to the landlord toward the purchase of the property.

### Example / Option 2:

Tenant pays \$750 for 20 years (240 months).

A total of \$180,000 will be paid to landlord at the end of the lease term.

Depending on the initial value of the property and expected appreciation, this may be more than enough to purchase the home. Therefore, if the tenant adheres to all terms of the agreement, the home is transferred at the end of the 20 years. No additional financing is necessary.



*Government rent-purchase programs are intended to help low-to-moderate income families buy homes. Private landlords also offer rent-purchase programs. Tenants should seek assistance and understand all the terms fully before signing.*

## Questions to Ask Before You Sign

Do I really want to buy this property? Does it meet my family's needs? Will it continue to meet my family's needs in the future?

Is the property worth the purchase price the landlord is asking? Get an appraisal. An appraisal should be done to determine the true value of the property before entering into an agreement.

Is the length of the agreement feasible? If I can't get financing now, what is the probability I will qualify for a loan later? Remember, Option 1 will require the tenant to pay the remaining balance at the end of the lease term. Buyers should be cautious of rent-purchase terms that exceed 30 years.

A traditional mortgage term for first-time homebuyers is 30 years.

How much of the rent payment is set aside (escrowed)? How can the funds be used? For example, will the funds go toward the down payment?

How much money will be due at the end of the lease term, if any?

What happens if I become delinquent on the monthly payments?

What happens with the escrow account if something changes, such as I can't get financing by the expiration date, or if I simply change my mind about buying? Will I lose the escrow funds?

## Menu

- 1 Are You Financially Ready to Rent?
- 2 The Ins & Outs of Credit
- 3 How to Find the Right Place
- 4 Handling the Application Process
- 5 Understanding the Lease Agreement
- 6 Getting Back Your Security Deposit
- 7 Life as a Renter: Rights & Responsibilities
- 8 Housekeeping, Maintenance & Repairs
- 9 The Right Way to Terminate the Lease

## Tips to Keep in Mind

Speak with a HUD-approved Housing Counselor before signing the lease agreement.

Review and understand all the details.

- ▶ Nonpayment recourse.
- ▶ Your responsibility as a tenant (maintenance, taxes, etc.).

Negotiate terms, if applicable.

Always pay on time!

Speak with a real estate professional and learn more about the community.

Schools.

Housing market in the area.

Take steps to correct any credit issues, if applicable.

Get loan approval at least six months prior to the expiration of the agreement.

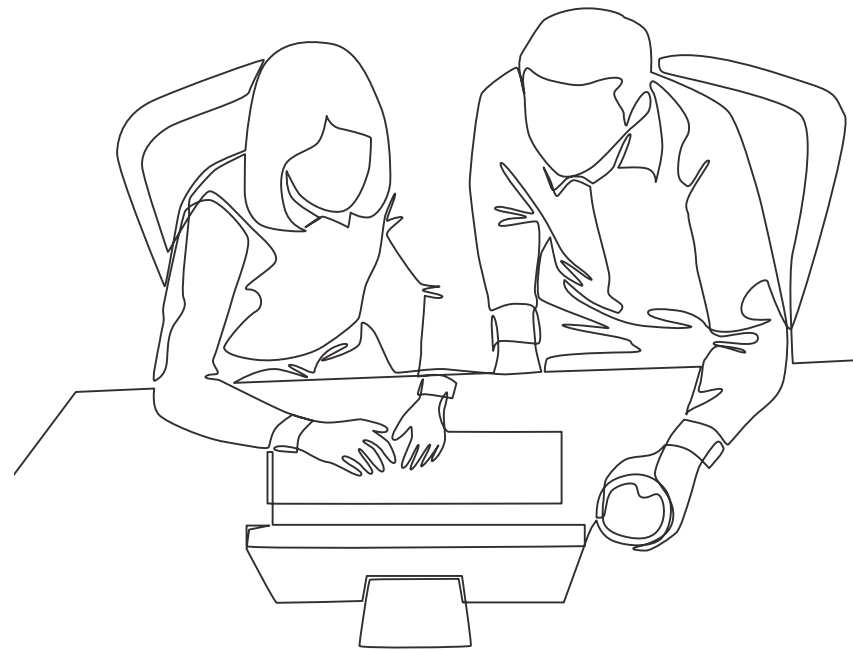

## Menu

- 1 Are You Financially Ready to Rent?
- 2 The Ins & Outs of Credit
- 3 How to Find the Right Place
- 4 Handling the Application Process
- 5 Understanding the Lease Agreement
- 6 Getting Back Your Security Deposit
- 7 Life as a Renter: Rights & Responsibilities
- 8 Housekeeping, Maintenance & Repairs
- 9 The Right Way to Terminate the Lease



**Test Your Knowledge.** Take the quiz for this chapter and get a certificate of completion! You'll be asked to create a user login, if you haven't already: <https://VirginiaHousinglearningcenter.mkscloud.com>



# Chapter 6

## Getting Back Your Security Deposit

Renting an apartment, house or any other type of residential unit usually requires a security deposit. It may be difficult, if not impossible, to rent if you're unable to pay this upfront cost. The key is planning ahead and taking a few strategic precautions. Often misunderstood, the security deposit is not the same as the last month's rent. This chapter examines this refundable cost and explains why the funds are required. It also details the landlord's responsibility to retain the funds while the tenant is an occupant, how the funds are used, and most importantly, the refund, after you've moved out.

### Menu

- 1 Are You Financially Ready to Rent?
- 2 The Ins & Outs of Credit
- 3 How to Find the Right Place
- 4 Handling the Application Process
- 5 Understanding the Lease Agreement
- 6 Getting Back Your Security Deposit
- 7 Life as a Renter: Rights & Responsibilities
- 8 Housekeeping, Maintenance & Repairs
- 9 The Right Way to Terminate the Lease

# What is a Security Deposit?

A security deposit is a refundable payment made to the landlord by the tenant before moving in. This amount is in addition to the first and last month's rent and other nonrefundable fees paid up front by an applicant. The payment is deposited into an account and held by the landlord until one of the following occurs:

- ▶ The applicant fails to rent the unit (never moves in).
- ▶ The applicant is denied rental by the landlord.
- ▶ The tenant moves out.

*Note: Although uncommon, the security deposit may be in the form of property if the landlord permits.*

## Return of the Security Deposit

*The security deposit must be refunded within 20 days if the applicant fails to rent. If the landlord rejects the application, the refund must be made within 20 day or 10 days if the deposit is paid by cash, certified check, cashier's check or postal money order.*

# What Can the Deposit Cover?

The security deposit is the landlord's protection against financial loss and liabilities. Because it's intended to secure compliance with the terms and conditions of the rental agreement, the landlord can use all or part of the security deposit to cover certain costs if the tenant is found to be in noncompliance. The landlord can use the security deposit, plus any accrued interest, to cover:

- ▶ **Early termination.** Whether written or verbal, the rental agreement will be for a specific time frame. Week-to-week and month-to-month agreements are intended to be indefinite until someone terminates them.

## Menu

- 1 Are You Financially Ready to Rent?
- 2 The Ins & Outs of Credit
- 3 How to Find the Right Place
- 4 Handling the Application Process
- 5 Understanding the Lease Agreement
- 6 Getting Back Your Security Deposit
- 7 Life as a Renter: Rights & Responsibilities
- 8 Housekeeping, Maintenance & Repairs
- 9 The Right Way to Terminate the Lease

A six-month or annual lease will have a beginning and ending date. When a tenant moves out early, the lease has been terminated early. Often, lease agreements have a provision that permits the landlord to charge an early termination fee, or to retain all or part of the tenant's security deposit.

- ▶ **Unpaid rent.** Landlords are entitled to all rent owed. Once the lease is terminated, the landlord can and will apply all or part of the security deposit to cover any amount still owed.
- ▶ **Late charges.** When rent isn't paid according to the lease agreement, a late charge is applied. The law allows landlords to charge a reasonable fee. Once the lease is terminated, the security deposit can be used toward any unpaid late charges.
- ▶ **Damages/excessive cleaning cost.** The tenant is expected to remove all personal property, repair or replace any tenant-caused damages and clean any excessively dirty areas before moving out of the dwelling. If not, the landlord may charge the tenant for any and all costs. You'll learn more about damages and cleaning later in this chapter.
- ▶ **Other Unpaid Charges.** If left unpaid when the tenant moves out, quite a few other costs can be deducted from the security deposit. These costs, discussed throughout this handbook, can include court costs and attorney's fees. If the tenant fails to pay utilities that were a part of their lease agreement, the security deposit can also be used to cover the unpaid portion.



*Tenants are not entitled to have the security deposit applied to unpaid rent, late fees and other costs while they are occupying the rental. While the landlord can deduct unpaid rent from the deposit, tenants should be discouraged from simply relying on that. They should pay the last month's rent so that their deposit will cover any damages there may be.*

## Menu

- 1 Are You Financially Ready to Rent?
- 2 The Ins & Outs of Credit
- 3 How to Find the Right Place
- 4 Handling the Application Process
- 5 Understanding the Lease Agreement
- 6 Getting Back Your Security Deposit
- 7 Life as a Renter: Rights & Responsibilities
- 8 Housekeeping, Maintenance & Repairs
- 9 The Right Way to Terminate the Lease

# Maximum Amount by Law

By law, the landlord can neither ask for nor accept a security deposit amount in excess of two months' rent. The maximum security deposit amount often varies with rent-subsidized properties and programs. The federal public housing program calculates the security deposit based on the minimum rent amount paid by the tenant, which is 30% of their income. Low-Income Housing Tax Credit programs also cap the amount that can be charged to program participants.

However, renters with Housing Choice Vouchers (HCV) can be charged a security deposit in excess of their part of the rent, but not to an amount that exceeds the maximum allowed by the Virginia Residential Landlord and Tenant Act (or, VRLTA). For example, if the tenant's rent amount is \$300 and the HCV Program's part is \$600, that equals a total monthly rent of \$900. This total permits the landlord to charge up to \$1,800 for the security deposit, since two times the rent amount is permitted by law. The HCV program is not responsible for any part of the deposit. (A description of the rental assistance programs can be found in Chapter 3, *How to Find the Right Place*.)

The landlord should provide a receipt for payment. If not, ask for a security deposit receipt that includes:

- ▶ Amount paid.
- ▶ Date paid.
- ▶ Intended use of the payment (i.e., security deposit).
- ▶ Property address.
- ▶ Property management company (if applicable).
- ▶ Landlord/owner.
- ▶ Name of person receiving the security deposit (i.e., agent/owner).

## Other Possible Upfront Costs

**Application fee.** Landlords often charge an application fee when you submit a rental application. This is a nonrefundable fee not to exceed \$32 for HUD-regulated properties (public housing), or \$50 per applicant for all other properties. This fee pays for the landlord's out-of-pocket expenses to cover the cost of a preoccupancy tenant screening. The screening may include a credit check, former landlord check and a criminal record check.

## Menu

- 1 Are You Financially Ready to Rent?
- 2 The Ins & Outs of Credit
- 3 How to Find the Right Place
- 4 Handling the Application Process
- 5 Understanding the Lease Agreement
- 6 Getting Back Your Security Deposit
- 7 Life as a Renter: Rights & Responsibilities
- 8 Housekeeping, Maintenance & Repairs
- 9 The Right Way to Terminate the Lease

# Menu

- 1 Are You Financially Ready to Rent?
- 2 The Ins & Outs of Credit
- 3 How to Find the Right Place
- 4 Handling the Application Process
- 5 Understanding the Lease Agreement
- 6 Getting Back Your Security Deposit
- 7 Life as a Renter: Rights & Responsibilities
- 8 Housekeeping, Maintenance & Repairs
- 9 The Right Way to Terminate the Lease

**Pet deposit.** There is no law prohibiting landlords from charging an upfront fee to tenants who have pets. With the exception of service animals as outlined by the Americans with Disabilities Act (ADA), landlords have the right to prohibit all or certain pets in the dwelling and on the premises. A pet deposit could be refundable.

**Pet rent.** Is charged on a monthly basis and is separate from the pet deposit. This monthly charge covers your pet actually being in your rental. In addition, pet rent is non-refundable.

**Damage insurance and renters insurance.** Damage insurance and renters insurance aren't the same. Damage insurance is coverage against losses arising from damages to the landlord's property caused by the renter. Renters insurance protects the renter's personal property and potential liability that may occur as a result of fire, theft, vandalism and other possible hazards or threats.

Landlords may require a tenant to secure damage insurance and/or a renters insurance policy. These policies are not considered a security deposit, but are rent. The total amount of the security deposit, damage insurance and renters insurance cannot exceed two months' rent. Tenants can elect to buy the policy from the landlord's insurer or get a separate policy through another insurer. The tenant must provide the landlord with proof of coverage. Regardless of whether the policies are paid on behalf of the tenant by the landlord, or paid directly by the tenant, the policy is issued in the name of the tenant. Landlords must provide a summary of the policy or certificate of coverage and, upon request, a copy of the damage insurance policy.

## Tiered-based Security Deposits

Can a landlord charge a different security deposit amount for the same dwelling? Yes! A landlord can charge one applicant a higher security amount, say \$900, and charge another applicant a lower amount, \$825, for an identical unit. The amount of the deposit can differ for various reasons. Commonly, it could be the result of an applicant's background check. As discussed in Chapter 2, The Ins and Outs of Credit, credit history reports and scores measure risk. The higher the credit score, the lower the risk. The lower the credit score, the higher the risk. Landlords want some assurance that the applicant will pay rent on time and follow the terms of the lease agreement. After reviewing the background check reports, the landlord has several options:



- ▶ Deny the application.
- ▶ Rent to the applicant with no special provisions.
- ▶ Rent to the applicant with a special, permissible provision, such as charging a higher security deposit.

In addition, landlords may offer and advertise, on a limited basis, special discounts such as reducing the security deposit for new move-ins. Neither are discriminatory practices. However, charging a different amount because of race, color, religion, national origin, sex, disability, familial status or elderliness is a violation of Virginia’s Fair Housing Act and against the law.

## Before You Move In

Inspect the premises thoroughly before moving in. Tenants must be willing to accept the property as is, with the only exception being conditions considered unsanitary, dangerous or a health risk. In most cases, landlords won’t permit tenants to make improvements or modifications to a dwelling. Always refer to your lease, or speak with the landlord directly, before making any changes to the dwelling, and always get approval in writing.

## Walk-through Inspection

**At move-in.** The landlord may provide the tenant with a pre-existing damage report within five days of occupancy; or state in the lease agreement that the property is in an acceptable condition. If the tenant receives a report, they must reply within five days and document any and all inconsistencies in the report. If the tenant fails to reply, then the landlord’s pre-existing report is deemed correct. It’s beneficial to begin inspecting the property right away. Start looking for any report discrepancies as you’re unpacking. Take pictures or videos of the property. Keep a journal and take notes as you begin to use appliances, plumbing, electrical outlets, etc.

As instructed in the lease agreement, be timely in submitting the report. Keep a copy for your records and double-check your list of discrepancies before submitting it to the landlord. The report should be signed by both you and the landlord. A well-documented inspection report will ensure that you’re not charged later for pre-existing conditions.

## Menu

- 1 Are You Financially Ready to Rent?
- 2 The Ins & Outs of Credit
- 3 How to Find the Right Place
- 4 Handling the Application Process
- 5 Understanding the Lease Agreement
- 6 Getting Back Your Security Deposit
- 7 Life as a Renter: Rights & Responsibilities
- 8 Housekeeping, Maintenance & Repairs
- 9 The Right Way to Terminate the Lease

Here are a few important inspection areas you'll want to pay attention to:

- ▶ Floors.
- ▶ Windows (to include blinds, if applicable).
- ▶ Ceilings.
- ▶ Furniture (if applicable).
- ▶ Doors.
- ▶ Cabinets.
- ▶ Appliances.
- ▶ Electrical.
- ▶ Plumbing.
- ▶ Ventilation.

**At move-out.** The landlord is required to make reasonable efforts to advise the tenant of the right to be present at the walk-through inspection. This notification must also be provided to the tenant with any request by the landlord to vacate. The right to inspect must also be provided within five days after you have notified the landlord of your intent to move out.

It is not necessary for the tenant to wait for a notice from the landlord to be present at the move-out inspection. You should notify the landlord in writing if you wish to exercise your right and be present during the inspection. Subsequently, the landlord must notify you of the time and date. The walk-through inspection must be conducted within 72 hours after the landlord has acquired possession.

## Security Deposit Refund

Landlords have 45 days to refund the deposit in *full* if all rent and other costs were paid and neither damages nor excessive cleaning cost were assessed. Security deposit refunds in non-VRLTA tenancies are controlled by the lease language. However, if the security deposit were applied against unpaid cost, damages, utilities, etc., then the landlord must detail in writing the part of the deposit that was withheld, itemizing each deduction and the amount. When the damages exceed the amount of the security deposit, the landlord has an additional 15 days to provide the tenant with this itemized list.

## Forwarding Address

It's important to provide a forwarding address in writing, prior to moving out. The landlord will mail your security deposit refund and itemized statement to the forwarding address you provide. In the absence of a forwarding address, the landlord will mail to the address of the property you've just vacated. In the case of co-tenants, one check payable to all tenants jointly is mailed to the address provided by one of the tenants.

## Menu

- 1 Are You Financially Ready to Rent?
- 2 The Ins & Outs of Credit
- 3 How to Find the Right Place
- 4 Handling the Application Process
- 5 Understanding the Lease Agreement
- 6 Getting Back Your Security Deposit
- 7 Life as a Renter: Rights & Responsibilities
- 8 Housekeeping, Maintenance & Repairs
- 9 The Right Way to Terminate the Lease

## Disputing the Deductions

You have the right to dispute any security deposit deductions made by the landlord. First, make sure you send the landlord a demand letter. In your letter, respond to each individual deduction. Provide specific details in the letter that explain why you disagree. Certified mail with return receipt is recommended because it requires your landlord to sign for it. Be sure to keep a copy for your records. Beware before cashing a partial return check. Include in the demand letter a statement that indicates the check will be or has been cashed, even though you're disputing the amount and the deductions.

## Seek Assistance

The landlord is noncompliant and in violation of the VRLTA if they fail to provide either the security deposit refund or an itemized list of deductions. The courts can order the return of the security deposit. In that situation, the case will be reviewed, and all factors and both sides will be heard. It's recommended that you seek assistance from either a HUD-approved Housing Counselor, Legal Aid or an attorney.

## Clean Up and Damages

Confirm your cleaning plans with your landlord so you don't end up under- or over-cleaning. Then clean up thoroughly and make an effort to fix any damage you, your pet or your guests have caused. It's also a good idea when you're done to take pictures or videos of the unit that document your cleaning and repair work.

In general, the landlord can't keep your security deposit for things considered normal wear and tear, such as small holes and spots that can be covered during painting and carpet cleaning. Landlords are expected to perform basic cleaning and/or may repaint prior to the new tenant moving in. However, they are not expected to remove trash and unwanted items such as clothing, appliances and furniture, remove food from refrigerators or clean an excessively dirty range. So, they can deduct these types of cleaning expenses from your security deposit:

## Menu

- 1 Are You Financially Ready to Rent?
- 2 The Ins & Outs of Credit
- 3 How to Find the Right Place
- 4 Handling the Application Process
- 5 Understanding the Lease Agreement
- 6 Getting Back Your Security Deposit
- 7 Life as a Renter: Rights & Responsibilities
- 8 Housekeeping, Maintenance & Repairs
- 9 The Right Way to Terminate the Lease

# Menu

- 1 Are You Financially Ready to Rent?
- 2 The Ins & Outs of Credit
- 3 How to Find the Right Place
- 4 Handling the Application Process
- 5 Understanding the Lease Agreement
- 6 Getting Back Your Security Deposit
- 7 Life as a Renter: Rights & Responsibilities
- 8 Housekeeping, Maintenance & Repairs
- 9 The Right Way to Terminate the Lease

## Types of Damage

- ▶ **Walls:** Holes from hanging pictures and other tenant damage; wallpaper, paint, stencils and other wall techniques done by the tenant.
- ▶ **Carpet:** Permanent or large stains from food, beverages and chemicals; tears and holes; burn marks from cigarettes, irons or other heat producing items; strong odors caused by pet urine.
- ▶ **Floors:** Damaged, stained; extensive water damage to hardwood floors.
- ▶ **Doors, windows and screens:** Holes, tears, cracks, broken; partially or fully off the hinges; missing.
- ▶ **Blinds:** Excessively dirty, damaged or missing.
- ▶ **Appliances:** Excessively dirty; exterior dents and large scratches; broken and missing parts such as racks or shelves.
- ▶ **Kitchen and baths:** Plumbing clogs.
- ▶ **Missing items:** Electrical socket and outlet covers; smoke/carbon monoxide detectors.
- ▶ **Pet issues:** Scratches on the molding and on or around doors; flea infestations caused by your pet.



**Test Your Knowledge.** Take the quiz for this chapter and get a certificate of completion! You'll be asked to create a user login, if you haven't already: <https://VirginiaHousinglearningcenter.mkscloud.com>

# Chapter 7

## Life as a Renter: Rights & Responsibilities

Whether a repeat renter or renting for the first time, you have rights, but you also have responsibilities. Most are outlined in the lease agreement. However, a few provisions are not. This chapter will discuss the Virginia Residential Landlord and Tenant Act (VRLTA). Specifically, a tenant's right to confidentiality, proper notifications and disclosures. The right to reasonable accommodation and modification for people with disabilities will also be discussed.

Decent, safe and sanitary housing is the right and responsibility of both the landlord and the tenant. Everyone wants to live in a reasonably quiet environment. Finally, this chapter will discuss a few key issues such as timely payment of rent, smoke and carbon monoxide detectors, extermination and painting.



## Menu

- 1 Are You Financially Ready to Rent?
- 2 The Ins & Outs of Credit
- 3 How to Find the Right Place
- 4 Handling the Application Process
- 5 Understanding the Lease Agreement
- 6 Getting Back Your Security Deposit
- 7 Life as a Renter: Rights & Responsibilities
- 8 Housekeeping, Maintenance & Repairs
- 9 The Right Way to Terminate the Lease



# Virginia Residential Landlord and Tenant Act (VRLTA)

The VRLTA establishes the rights and obligations of both the landlord and tenant for all residential rental properties in Virginia. Landlords with two or fewer units have the option to opt out from the VRLTA, but not the law. However, this doesn't mean that a tenant who rents a property exempt from VRLTA has no rights, remedies and responsibilities; often there are local, county and municipal ordinances to assist and protect these tenants. In addition, provisions are defined by Virginia's general landlord and tenant law (Code of Virginia).

In general, apartments, motels, boarding houses and single-family houses are covered by the Act. The rights and responsibilities outlined in this chapter will focus on rentals covered by the VRLTA, including:

- ▶ Apartment units and buildings.
- ▶ Single-family houses.
- ▶ Motels and boarding houses (only when the occupant has resided in the dwelling for more than 90 days).

Parts of the VRLTA also apply to manufactured homes, public housing and Section 8 rental units. More on manufactured homes can be found in the Virginia Manufactured Home Lot Rental handbook. Contact the local Housing Authority or Housing Agency in your area for more information about federally regulated subsidized housing.

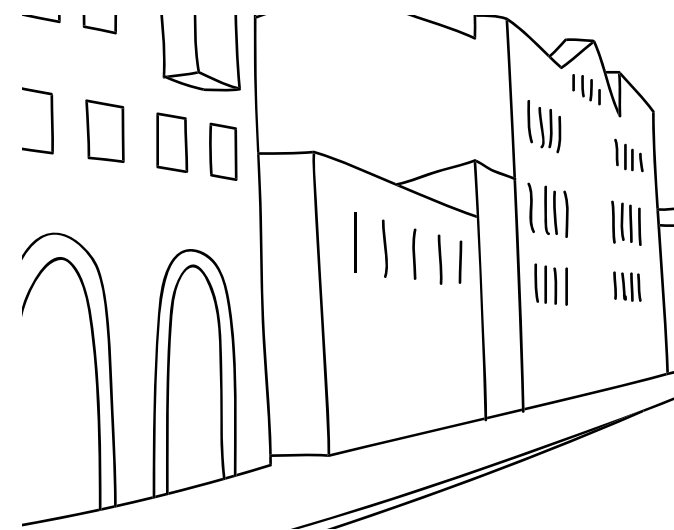

*Wording in the rental agreement asking tenants to waive or forego their rights or remedies under the VRLTA is prohibited.*

## Menu

- 1** Are You Financially Ready to Rent?
- 2** The Ins & Outs of Credit
- 3** How to Find the Right Place
- 4** Handling the Application Process
- 5** Understanding the Lease Agreement
- 6** Getting Back Your Security Deposit
- 7** Life as a Renter: Rights & Responsibilities
- 8** Housekeeping, Maintenance & Repairs
- 9** The Right Way to Terminate the Lease

# Confidentiality

Information about an applicant or renter may not be shared with a third party. You have the right to confidentiality. This means your name, address, payment history and other record of information cannot be released arbitrarily. Remember that matters of public record, such as court documents, are accessible to anyone. For example, delinquent rent that results in a court matter will be recorded by the clerk of courts and be visible to the public. This includes other material noncompliance notices and termination notices.

You, as an applicant and a tenant, must provide your potential and current landlord with written consent in order for them to release personal information. An example of when you might want your landlord to release this information might be if the neighborhood school needs verification of your residency prior to registering a child in your household as a student.

Confidentiality is not observed in the case of an emergency, or when information is requested by:

- ▶ Law-enforcement.
- ▶ Public safety officials.
- ▶ Revenue commissioner.
- ▶ Contract purchaser.
- ▶ Landlord’s attorney (to include information requested pursuant to a civil case subpoena).
- ▶ Landlord’s lender (for the purpose of financing or refinancing of the property).
- ▶ Military (commanding officers, housing officer and attorneys).

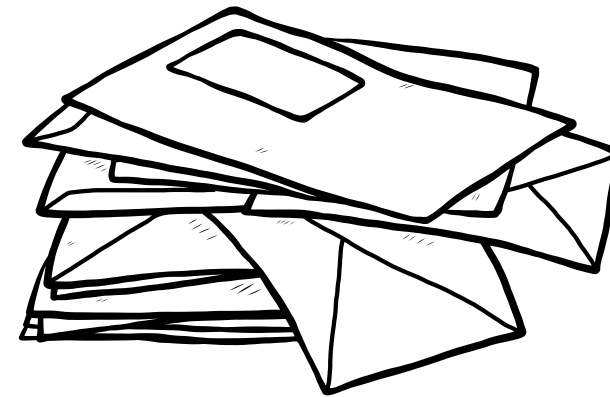

# Notices

Both you and the landlord must take reasonable steps to inform each other of rental issues. Reasonable steps include but are not limited to:

- ▶ Written documentation sent by mail.
- ▶ Hand-delivered notification.
- ▶ Electronic notification (if the lease permits).
- ▶ Verbal notice.

## Menu

- 1 Are You Financially Ready to Rent?
- 2 The Ins & Outs of Credit
- 3 How to Find the Right Place
- 4 Handling the Application Process
- 5 Understanding the Lease Agreement
- 6 Getting Back Your Security Deposit
- 7 Life as a Renter: Rights & Responsibilities
- 8 Housekeeping, Maintenance & Repairs
- 9 The Right Way to Terminate the Lease

Keep in mind that neither party (you nor the landlord) needs to provide proof that the other has actually read the contents of the written notification; only that sufficient notice was delivered. This burden of proof may include a certificate of mailing, an electronic receipt or a fax confirmation. Being able to prove that a verbal notice was delivered is difficult, if not impossible. That's why, in some circumstances, verbal notification is not recommended. However, in some cases if the receiving party acknowledges receiving verbal notification, this is deemed proof of notification. Keep in mind, that the law and/or the lease require certain notices to be in writing and, therefore, cannot be verbal.



*Landlords only need to mail notifications to your last known place of residency. When moving out, always provide a forwarding address!*

## Disclosures

Below is a list of disclosures required by the VRLTA. The disclosed information may be a clause within the lease agreement or an entirely separate document.

**Persons authorized to enter the unit.** Landlords must disclose to you the name and address of any and all people authorized to manage the premises, the owners and any other authorized persons. The disclosure must be in writing and submitted to you on or before the date the lease begins. You will learn more about entry right later in this section.

**Sale of the premises.** You have the right to be informed when/if the property is sold. The disclosure must include the name, address and phone number of the new owner and/or management company.

**Tenant displacement (property demolition, rehab or conversion).** Landlords must disclose in writing the registration of a property as a condo or cooperative (co-op). In addition, as a prospective tenant, you must be informed if the landlord has any plans within six months to demolish, rehabilitate or convert the property. Changing the property from a residential rental unit to an office, hotel or planned unit development is considered a conversion.

**Properties located adjacent to a military air installation.** A county or city zoning office may designate a property to be in a "noise zone" or "accident potential zone." As a prospective tenant, the landlord must provide you notice of the zoning designation prior to occupancy.

## Menu

- 1 Are You Financially Ready to Rent?
- 2 The Ins & Outs of Credit
- 3 How to Find the Right Place
- 4 Handling the Application Process
- 5 Understanding the Lease Agreement
- 6 Getting Back Your Security Deposit
- 7 Life as a Renter: Rights & Responsibilities
- 8 Housekeeping, Maintenance & Repairs
- 9 The Right Way to Terminate the Lease

**Properties with defective drywall.** Drywall is a building component used to construct walls and ceilings of apartments and other dwellings. Drywall panels are typically made from plaster pressed between thick sheets of paper. In 2001, builders used a drywall product manufactured in China and imported to the United States. Known as Chinese drywall, these panels were later found to be environmentally unsafe and were banned in the U.S. Not all drywall made in China is defective. However, defective drywall, reported to smell like rotten eggs, has a severe impact on human health. These panels give off a dangerous gas that has caused occupants to have respiratory and sinus problems, bloody nose, eye irritation, headaches, and, in some cases, lung cancer. The gas also destroys pipes, wiring, coils, plumbing and other components of the dwelling. The landlord is required to notify you in writing if a dwelling contains toxic Chinese drywall.

**Other disclosures:** Other disclosures include whether there is a history of mold, lead paint or methamphetamine.

## Right of Entry

You have the right to privacy. That means it is the responsibility of the landlord, the landlord's agent, maintenance personnel and contractors to enter the unit only as outlined in the lease agreement. It is your responsibility to allow access to your unit. Refusing entry can result in a noncompliance issue and any subsequently applicable charges, including attorney fees. Unlawful entry or abuse of entry by the landlord should be reported to authorized entities, such as the property management company, fair housing authorities or law enforcement. This unlawful or abusive conduct may include unreasonable entry or repeated demands for entry. Except in cases of emergencies or matters of urgency, early morning or late evening entry may be deemed unreasonable.

## Menu

- 1 Are You Financially Ready to Rent?
- 2 The Ins & Outs of Credit
- 3 How to Find the Right Place
- 4 Handling the Application Process
- 5 Understanding the Lease Agreement
- 6 Getting Back Your Security Deposit
- 7 Life as a Renter: Rights & Responsibilities
- 8 Housekeeping, Maintenance & Repairs
- 9 The Right Way to Terminate the Lease

# Decent, Safe and Sanitary Rental

Ensuring that your rental unit is decent, safe and sanitary is the ongoing responsibility of both the landlord, and you, the tenant. This responsibility typically refers to applicable building and housing codes that affect tenant health and safety. To comply with codes, landlords are required to perform certain duties in accordance with law.

You also have responsibilities. Treat the property with the same respect you would if it were your own. Notify the landlord right away if there are plumbing, electrical, gas, heating and/or HVAC problems. Don't allow problems to escalate into major repair or replacement issues. Take reasonable steps to stop additional damage and prevent a costly maintenance issue that could turn into an unlivable situation. Typically, you'll be held responsible for minor repairs.

Here are some responsibilities of the landlord and tenant to ensure the property remains decent, safe and sanitary:

LANDLORD	TENANT
Keep all common areas clean and structurally safe.	Keep all occupied and used areas (interior and exterior) clean and safe.
Maintain facilities such as the electrical, plumbing, heating, etc., to keep them in good, safe and proper working order.	Use all utilities in a reasonable manner. Keep all plumbing fixtures clean and clog-free. Keep services on.
Maintain appliances in good, safe and proper working order.	Use all appliances in a reasonable manner.
Maintain the premises in such a condition as to prevent the accumulation of moisture and growth of mold.	Make reasonable efforts to prevent the accumulation of moisture and growth of mold. Promptly notify the landlord if mold develops.
Provide and maintain receptacles in common areas for multiple units.	Remove ashes, garbage, rubbish and other waste safely and use the receptacles provided.

## Menu

- 1 Are You Financially Ready to Rent?
- 2 The Ins & Outs of Credit
- 3 How to Find the Right Place
- 4 Handling the Application Process
- 5 Understanding the Lease Agreement
- 6 Getting Back Your Security Deposit
- 7 **Life as a Renter: Rights & Responsibilities**
- 8 Housekeeping, Maintenance & Repairs
- 9 The Right Way to Terminate the Lease





LANDLORD	TENANT
Supply running water, reasonable hot water, reasonable air conditioning (if provided).	
Deliver a dwelling free of insects and pests, including in common areas.	Keep dwelling free from insects and pests, and promptly notify the landlord if pests are discovered.

## Disabled Tenant or Household Member

The specific rights of legally disabled tenants or household members are outlined in the Virginia Fair Housing Act, the Americans with Disabilities Act and the Virginia Residential Landlord and Tenant Act. Each of these acts gives you or a household member the right to a “service animal,” “reasonable accommodations” and “reasonable modifications.”

Even landlords with a no-pet policy must allow service animals. A service animal is defined as an animal specially trained and for the benefit of the disabled person. A certification is not required, and there are no limitations to the breed or size of the service animal. In addition, the landlord can’t charge a pet deposit or any other kind of fee related to the animal. However, you will be responsible for any damages caused by the service animal. Although these legal rights are provided for the disabled tenant, occupants still must follow rules that protect the safety of others. This includes applicable leash laws, vaccination mandates, waste disposal, noise control and licensing requirements.

**Your right to reasonable accommodations.** Reasonable accommodations are exceptions to the landlord’s rules, policies, practices or services. Reasonable modification refers to structural changes, such as the installation of ramps and/or grabs bars. The landlord is responsible for honoring reasonable requests as allowed under state and federal law. The tenant may be responsible for restoring property after a reasonable modification.

## Menu

- 1 Are You Financially Ready to Rent?
- 2 The Ins & Outs of Credit
- 3 How to Find the Right Place
- 4 Handling the Application Process
- 5 Understanding the Lease Agreement
- 6 Getting Back Your Security Deposit
- 7 Life as a Renter: Rights & Responsibilities
- 8 Housekeeping, Maintenance & Repairs
- 9 The Right Way to Terminate the Lease



However, the costs of modifications — which can be expensive — are usually your responsibility. There are some exceptions for federally funded property. You should seek out specific loans or grant programs to help with modification costs.



*Recognizing the need for affordable, accessible housing, Virginia Housing offers Rental Unit Accessibility Modification grants to eligible applicants. Visit our website at [VirginiaHousing.com/ruam](https://VirginiaHousing.com/ruam) and [VirginiaHousing.com/grantingfreedom](https://VirginiaHousing.com/grantingfreedom) to learn more.*

Keep in mind that what may seem reasonable to you can seem unreasonable to the landlord. The Department of Justice (DOJ) and the Department of Housing and Urban Development (HUD) have a statement that provides technical assistance regarding ADA rights and the obligations of housing providers to people with disabilities relating to reasonable modification. You may also want to refer to the Acts mentioned above, or seek assistance from industry professionals such as a Center for Independent Living (CIL), a local Housing Authority or an attorney.



## Utilizing the Premises

When utilizing the premises, be aware of these considerations:

### Quiet Surroundings

You have the right to reasonably quiet surroundings and to not be disturbed by neighbors. Remember that your neighbors have the same rights. The goal is to ensure that everyone's right to peaceful enjoyment of the premises is protected. This means that you, as well as your neighbors, are responsible for:

- ▶ Your conduct.
- ▶ The conduct of all family members who occupy your dwelling.
- ▶ The conduct of your guests.

## Menu

- 1 Are You Financially Ready to Rent?
- 2 The Ins & Outs of Credit
- 3 How to Find the Right Place
- 4 Handling the Application Process
- 5 Understanding the Lease Agreement
- 6 Getting Back Your Security Deposit
- 7 Life as a Renter: Rights & Responsibilities
- 8 Housekeeping, Maintenance & Repairs
- 9 The Right Way to Terminate the Lease

## Authorized Occupants

Only those listed on the lease agreement are authorized occupants. Anyone other than you and your listed occupants would be considered an unauthorized guest. Guests staying on the premises overnight for long periods may be considered unauthorized occupants. The lease agreement should provide the maximum stay provisions for overnight guests. You should consult with your landlord immediately for any guests you expect to stay for a lengthy amount of time.

## Residential Dwelling

In addition, you may occupy the dwelling only as a residence. Operating businesses such as daycare services, or performing automobile repair for money, are often a violation of the lease agreement. Consult with the landlord prior to operating any business from the home or on the premises. Under no circumstance should the dwelling be used for any type of unlawful activity.

## Rent

Rent is essential to your ability to enjoy the premises.

Your most important responsibility is to pay rent in full and on time. The lease agreement will provide the specifics of when the rent is due, the amount, to whom it is to be paid and where to make the payment. Payments by check or money order should include your address and the rent month. If paying by cash or money order, you have the right to request a written receipt of payment. The receipt should include the date of payment, the month the payment is for and the amount of the payment.

You will be responsible for any additional charges (as outlined in the lease agreement) when payment is not received by the due date or if a partial payment is submitted. Tenants who submit payment with insufficient funds are subject to a return check fee amount, as outlined in the lease agreement. In addition, landlords could require tenants to make all future payments with guaranteed funds, such as money orders or a certified or cashier's check.



*It is not true that mailed payments need only be postmarked by the due date. Landlords want the payment in hand by the due date. There is no postmark date rule unless specified in the lease.*

## Menu

- 1 Are You Financially Ready to Rent?
- 2 The Ins & Outs of Credit
- 3 How to Find the Right Place
- 4 Handling the Application Process
- 5 Understanding the Lease Agreement
- 6 Getting Back Your Security Deposit
- 7 Life as a Renter: Rights & Responsibilities
- 8 Housekeeping, Maintenance & Repairs
- 9 The Right Way to Terminate the Lease

# Advance or Prepaid Rent

You may offer to pay rent in advance; this is also known as prepaid rent. If the landlord accepts the offer, they are required to place the prepaid rent into an escrow account. Once received, the landlord must deposit the prepaid rent in a Virginia federally-insured bank by the fifth business day. The funds must remain in the account and are withdrawn only when the prepaid rent amount is due.

**Example:**

Gayle currently pays \$700 a month for rent. She offered, and the landlord accepted, her current January rent payment in addition to her February and March rent payments — a total of \$2,100 (\$700 x 3).

A deposit of \$1,400 is placed into an escrow account. On February 1 the landlord will withdraw \$700, and on March 1 the landlord will withdraw the \$700 balance.

# Rent Increase

Note that even if you prepay, your rent amount may be subject to increase. You have the right to receive at least 30 days' advance notice if and when the landlord intends to raise the rent. In addition, the landlord can't raise the rent until the lease term has expired.

# Locks and Peepholes

The installation of locks and peepholes is governed by the city, county or town in which the rental is located and may only apply to landlords who rent five or more units in one building. Localities refer to the Uniform Statewide Building Code (USBC), which contains regulations regarding new construction, existing buildings and additions, and the maintenance and repair of buildings. The code addresses manufacturers' locks, deadbolt locks, peepholes and window locks, along with removable pins or Charlie bars for exterior sliding glass doors. Doors

## Menu

- 1 Are You Financially Ready to Rent?
- 2 The Ins & Outs of Credit
- 3 How to Find the Right Place
- 4 Handling the Application Process
- 5 Understanding the Lease Agreement
- 6 Getting Back Your Security Deposit
- 7 Life as a Renter: Rights & Responsibilities
- 8 Housekeeping, Maintenance & Repairs
- 9 The Right Way to Terminate the Lease

with glass panels don't require a peephole. You should contact the local municipal office with questions regarding locks and peepholes.

## Keys

The landlord will issue each tenant one set of keys. You are not permitted to change or install additional locks without the landlord's prior permission. The few exceptions where prior permission is not required include:

- ▶ You have an emergency situation.
- ▶ You have received a court order excluding one or more tenants or authorized occupants from the premises.

However, if you do change or install additional locks, it is your responsibility to provide the landlord a key within 24 hours. The original key and any copies must be returned when you move out.

## Smoke and Carbon Monoxide Detectors

It is the landlord's responsibility to install an operable smoke detector and carbon monoxide detector. It's your responsibility to maintain these devices. Under no circumstance should you remove or tamper with these devices. This includes removing working batteries.

## Extermination

The landlord must provide tenants with written notice 48 hours before they intend to exterminate the unit. This includes posting notices throughout the apartment complex. It's your responsibility to notify the landlord if insecticides or pesticides pose a health problem. It's also your responsibility to prepare the unit as instructed. The 48-hour notice is not required if you request the extermination.

## Menu

- 1 Are You Financially Ready to Rent?
- 2 The Ins & Outs of Credit
- 3 How to Find the Right Place
- 4 Handling the Application Process
- 5 Understanding the Lease Agreement
- 6 Getting Back Your Security Deposit
- 7 Life as a Renter: Rights & Responsibilities
- 8 Housekeeping, Maintenance & Repairs
- 9 The Right Way to Terminate the Lease



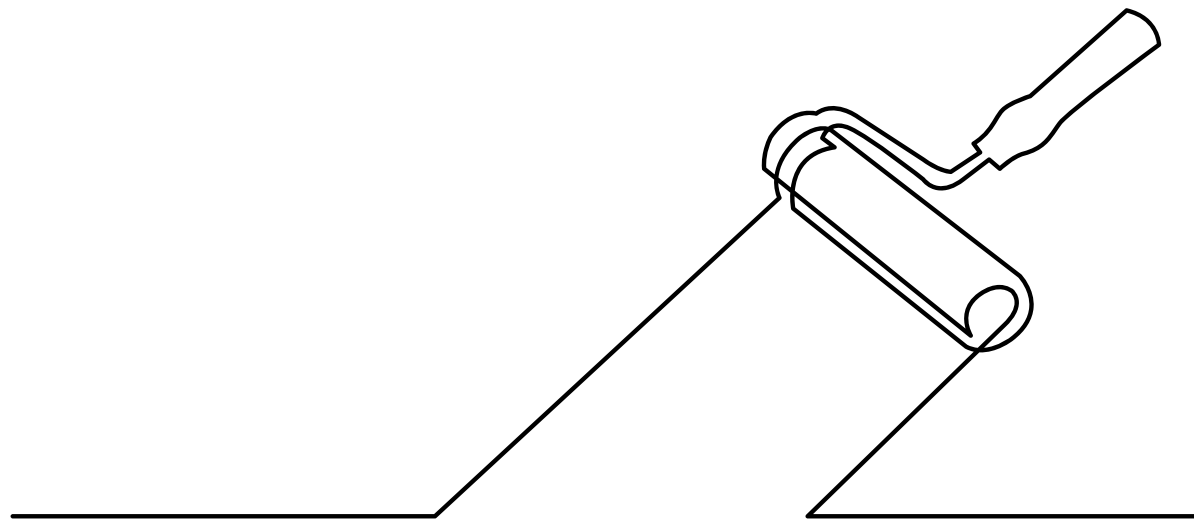

## Painting and Alterations

In many cases, the tenant is not permitted to paint or make alterations to the dwelling. You should always get prior written authorization before making changes. Making alterations to dwellings built prior to 1978 are a specific concern, since they were often painted with lead-based paint that may pose a health risk if exposed. Landlords must provide the tenants with a lead-based paint disclosure. Unauthorized painting and alterations can, and often will, affect the return of your security deposit. For more lead-based paint information, visit HUD's website.



**Test Your Knowledge.** Take the quiz for this chapter and get a certificate of completion! You'll be asked to create a user login, if you haven't already: <https://VirginiaHousinglearningcenter.mkscloud.com>

## Menu

- 1 Are You Financially Ready to Rent?
- 2 The Ins & Outs of Credit
- 3 How to Find the Right Place
- 4 Handling the Application Process
- 5 Understanding the Lease Agreement
- 6 Getting Back Your Security Deposit
- 7 Life as a Renter: Rights & Responsibilities
- 8 Housekeeping, Maintenance & Repairs
- 9 The Right Way to Terminate the Lease

# Chapter 8

## Housekeeping, Maintenance & Repairs

Not being the owner of the property doesn't mean you don't have responsibilities for the care of the property. In fact, keeping the rental property in good condition is the shared responsibility of both you and your landlord. Housekeeping is the everyday task of cleaning and organizing. Maintenance is the routine work necessary to keep your rental in good working order. Home maintenance is not optional; it is necessary. Necessary repairs, of course, fix damaged items, but also preserve the usefulness of the dwelling's operating systems, appliances and other components.

This chapter reviews these important responsibilities. Performing daily, routine and periodic tasks will ensure the health and safety of the dwelling occupants, along with preserving the value of the property.

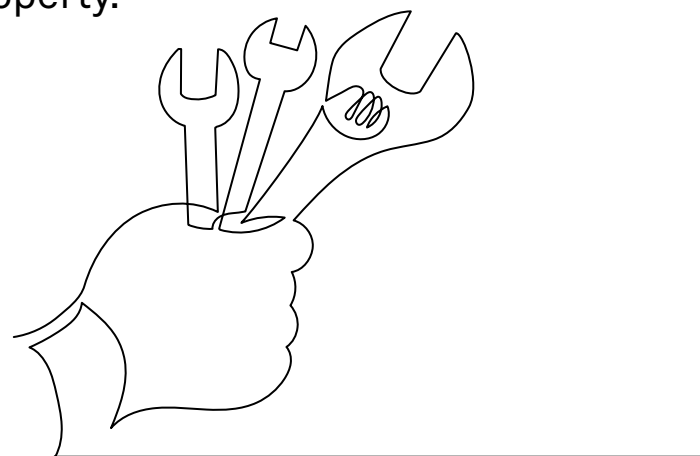

## Menu

- 1 Are You Financially Ready to Rent?
- 2 The Ins & Outs of Credit
- 3 How to Find the Right Place
- 4 Handling the Application Process
- 5 Understanding the Lease Agreement
- 6 Getting Back Your Security Deposit
- 7 Life as a Renter: Rights & Responsibilities
- 8 Housekeeping, Maintenance & Repairs
- 9 The Right Way to Terminate the Lease

# Building and Housing Codes

Building and housing codes set specific standards for all property owners to protect citizen health and safety. State and local ordinances often address ventilation, heating, water, lighting, weatherproofing, plumbing and electrical systems. These codes vary across the state. For example, some localities may or may not have certain requirements regarding smoke detectors, locks, keys and peepholes. A local housing authority, health department or fire department can provide specific information for the cities and counties within their jurisdiction. Landlords are expected to follow all applicable laws and, if they do not, they're subject to fines and other penalties.

# Landlord's Responsibilities

The health and safety of the dwelling occupants is the primary responsibility of the landlord. Of course, landlords are not expected to perform housekeeping tasks, but they are expected to carry out routine maintenance and needed repairs. "Habitable conditions" include the interior and exterior of the dwelling.

The rental unit's operating systems, appliances and other amenities can affect the safety and health of occupants if not maintained properly, so it's critical to keep these household necessities and conveniences in working order. Not only is electricity an important necessity, but its improper use, lack of maintenance and defects can cause shocks, burns and fires. Equally important is the dwelling's plumbing system. If the water heater temperature is set too high, the water used for consumption and hygiene could cause skin burns and scalding. The recommended setting is no higher than 120 degrees Fahrenheit. In addition, water leaks from pipes, faucets, toilets and other plumbing components could cause property damage that could result in harm to occupants. Water contaminants that cause sickness, disease or even death could arise from plumbing issues, making them a major health concern.

## Home Appliances

Safety hazards can arise from homes appliances as well. According the U.S. Consumer Product Safety Commission, dishwashers are one of the most dangerous household appliances. The appliance can harbor bacteria and allow children access to knives and

## Menu

- 1 Are You Financially Ready to Rent?
- 2 The Ins & Outs of Credit
- 3 How to Find the Right Place
- 4 Handling the Application Process
- 5 Understanding the Lease Agreement
- 6 Getting Back Your Security Deposit
- 7 Life as a Renter: Rights & Responsibilities
- 8 Housekeeping, Maintenance & Repairs
- 9 The Right Way to Terminate the Lease



other utensils left inside. In addition, other appliances such as ranges, refrigerators and dryers could overheat and short circuit. Dryers have been known to catch fire from excessive lint buildup while in use. Electrical failure or product defects may cause appliance fires as well. Also, older model refrigerators and freezers can trap children inside.

### Exterior Maintenance

Routine exterior maintenance will vary according to the type of dwelling. In the case of a single-family home, routine maintenance could be the divided responsibility of both the landlord and the tenant. For example, the landlord performs seasonal gutter cleaning and structural upkeep for items such as stair railings. The tenant might be expected to maintain the lawn, which could include mowing and weed removal. However, in an apartment complex the landlord would be expected to perform most, if not all, exterior maintenance. Providing trash receptacles and garbage removal is a responsibility of all landlords who must comply with the Virginia Residential Landlord and Tenant Act. Insect and rodent infestations are also important health concerns, and will be discussed later in this chapter.



*Common areas are spaces and facilities used by more than one tenant. Examples include parking lots, hallways, elevators, playgrounds and community buildings. These common areas are typically found in apartment complexes, townhomes and condos. It is the responsibility of the property management company, Homeowner's Association (HOA), or Condominium (Condo) Association to keep these areas clean and structurally safe.*

## Tenant's Responsibilities:

Your primary responsibility as the tenant is to perform housekeeping tasks and to:

- ▶ Keep the property clean and sanitary.
- ▶ Operate appliances, fixtures and other components correctly.
- ▶ Perform routine and other home maintenance as described in the lease agreement
- ▶ Use the operating systems correctly (electrical, plumbing, heating and air conditioning).

## Menu

- 1 Are You Financially Ready to Rent?
- 2 The Ins & Outs of Credit
- 3 How to Find the Right Place
- 4 Handling the Application Process
- 5 Understanding the Lease Agreement
- 6 Getting Back Your Security Deposit
- 7 Life as a Renter: Rights & Responsibilities
- 8 Housekeeping, Maintenance & Repairs
- 9 The Right Way to Terminate the Lease



*An “as-is” lease agreement often states that the tenant is responsible for all maintenance and repairs. Always make sure to fully read and understand your lease.*

### **Keeping the Property Clean and Sanitary**

Everyone would probably agree that a clean home looks better than a dirty one. But cleaning your rental property is about more than looks. Cleaning kills bacteria and removes harmful hazards. Kitchen and bathroom (disinfectant) cleaning products can reduce or eliminate the spread of viruses and kill germs that can cause illnesses. It’s important to clean glass shower doors directly after showering with a squeegee or daily spray cleaner. Sweeping and mopping floors and vacuuming and shampooing carpets can remove bacteria as well as small items that could become a hazard. Small children may choke on debris, and anyone could trip or slip on items and spills.

Regular laundering of clothing, bedding (including mattress pads) and bath and hand towels is equally important. Washing dishes immediately and disposing of trash properly helps eliminate potential insect and rodent issues. Always keep food sealed tightly — especially food kept in cabinets and pantries — and throw away expired food promptly. Pest infestation can quickly spread from unit to unit.

Good housekeeping habits are important for everyone. Keeping the property clean and sanitary should be a special concern for asthmatic occupants, as well as in dwellings with small children, disabled and elderly occupants.

### **Routine Home Maintenance**

Always make sure to fully read and understand your lease. With continual use of fixtures and amenities, normal wear and tear is to be expected. However, tenants are expected to care for fixtures and amenities by performing routine maintenance. Weekly, quarterly, seasonal and even annual maintenance can often extend the life of many home appliances, provided they’re used properly. While interior and exterior maintenance is often a shared responsibility between landlord and tenant, some maintenance tasks may be the sole responsibility of you as the tenant.

## Menu

- 1 Are You Financially Ready to Rent?
- 2 The Ins & Outs of Credit
- 3 How to Find the Right Place
- 4 Handling the Application Process
- 5 Understanding the Lease Agreement
- 6 Getting Back Your Security Deposit
- 7 Life as a Renter: Rights & Responsibilities
- 8 Housekeeping, Maintenance & Repairs
- 9 The Right Way to Terminate the Lease





Some tasks you are likely to be responsible for include:

- ▶ Dusting ceiling fans and cleaning light globes.
- ▶ Cleaning windows.
- ▶ Removing debris from exterior components, such as an air conditioning unit.
- ▶ Keeping sidewalk and other common areas clear of personal items, such as children's toys.
- ▶ Picking up after pets.
- ▶ Disposing of trash in receptacles provided.
- ▶ Removing debris from the yard.
- ▶ Complying with the lease agreement and/or codes regarding abandoned and disabled vehicles.

### Operating Systems

A dwelling's standard operating systems include electricity, plumbing and heating. Landlords are required to provide adequate ventilation, but not necessarily an air conditioning unit or central air. Tenants who are responsible for the payment of any utilities (as outlined in the lease agreement) must pay the service provider on time. Disconnection for nonpayment is often a violation of the lease agreement. Cleaning vents and changing filters are often the responsibility of the tenant. These routine maintenance tasks will keep dust and dirt from accumulating. This allows the systems to operate more efficiently and helps the occupants breathe easier. Because constantly turning an air conditioning unit on and off can cause the system to malfunction, it's recommended that you set thermostats at a comfortable temperature and leave them there. Newer models can be set on an automatic schedule to adjust throughout the day. This is an excellent way to reduce your energy bill as well. Ask the property owner for assistance if needed. The Preventive Maintenance section of this chapter provides more information on the upkeep of the dwelling's operating systems.

### Appliances and Fixtures

The appliances, fixtures and other components furnished by landlords can vary. It is typical for a range (stove) to be included. However, you may or may not have a model with a self-cleaning oven. Refrigerators are also an appliance tenants can expect to be furnished when renting from an apartment complex, but it may not be included when renting a single-family home.

Routine maintenance of these appliances starts with keeping them clean from dust, dirt and grime. This includes microwave ovens, dishwashers, washers and dryers. If left unattended, spills in or on the refrigerator, range and microwave can cause permanent stains. Be sure to check

## Menu

- 1 Are You Financially Ready to Rent?
- 2 The Ins & Outs of Credit
- 3 How to Find the Right Place
- 4 Handling the Application Process
- 5 Understanding the Lease Agreement
- 6 Getting Back Your Security Deposit
- 7 Life as a Renter: Rights & Responsibilities
- 8 Housekeeping, Maintenance & Repairs
- 9 The Right Way to Terminate the Lease

appliances and fixtures regularly for cracks, damages, leaks, frayed wiring and hose connections, in addition to changing filters and lint traps often.

Remember to use appliances and fixtures properly. For example:

- ▶ Never overload the washer or dryer.
- ▶ Never heat nonfood items in the microwave.
- ▶ Never use the toilet to dispose of nonwaste items.  
(Discarding cooking oil down a toilet or sink is a big “no-no!”)

### Reporting Problems

If there is a problem, you must be sure to report it promptly. Remember, the landlord has a responsibility to perform certain maintenance jobs and make needed repairs. Periodic inspections of the premises by the landlord can detect problems. However, problems can still arise. It’s your responsibility, as the tenant, to let the landlord know as soon as possible if something is wrong. Taking care of problems earlier, rather than later, benefits everyone. For example, a frayed appliance wire, if reported early, could simply be replaced by a professional. However, if left uncorrected the wire could eventually cause the appliance to stop working and require replacement of the entire unit. The worst-case scenario? The frayed wired could cause an electrical fire, resulting in possible harm to occupants and extensive property damage.

Tenant-caused problems, such as clogged plumbing, may cause you to not want to report the problem for fear of being charged for the repair cost or being evicted. Even so, under no circumstance should you ever delay or not report problems. Delays can cause unnecessary risk to the occupants, and small problems can become larger problems and more costly.



*Always report problems or concerns as outlined in the lease agreement. Any follow-up should be documented by written notification or via email. Retain a copy for your records.*

## Menu

- 1 Are You Financially Ready to Rent?
- 2 The Ins & Outs of Credit
- 3 How to Find the Right Place
- 4 Handling the Application Process
- 5 Understanding the Lease Agreement
- 6 Getting Back Your Security Deposit
- 7 Life as a Renter: Rights & Responsibilities
- 8 Housekeeping, Maintenance & Repairs
- 9 The Right Way to Terminate the Lease

Do not attempt repairs unless you are qualified and have authorization from the landlord. Listed below are common problems and the most likely cause of each.

Problem:	Often a sign of:
Flickering lights.	Poor circuit connection.
Frequently blown fuses.	Overloaded circuits.
Loose-fitting plug outlets.	Poor installation or deterioration.
Dripping faucet.	Worn washer.
Slow sink or tub drains.	Hair or debris buildup.
Running toilets.	Overflow valve, loose flapper chain or seal.
Leaking toilets.	Old or worn seals.
Overflowing toilet.	Minor or major clog.
Low water pressure.	Blocked aerator (calcium buildup).
Jammed garbage disposal.	Food trapped in waste discharge.
Leaking hot water tank.	Rusted bottom (replacement only).
No hot water.	Unlit pilot or low temperature setting.
House not cooling.	Clogged filter, AC low on refrigerant.
Leaky air conditioner (central).	Defective drain hose, condensation pump.

## Menu

- 1 Are You Financially Ready to Rent?
- 2 The Ins & Outs of Credit
- 3 How to Find the Right Place
- 4 Handling the Application Process
- 5 Understanding the Lease Agreement
- 6 Getting Back Your Security Deposit
- 7 Life as a Renter: Rights & Responsibilities
- 8 Housekeeping, Maintenance & Repairs
- 9 The Right Way to Terminate the Lease



# Landlord Negligence

Once you have reported any health concerns, maintenance issues or needed repairs, you must give the landlord a reasonable amount of time to resolve them. What is considered reasonable can be hard to define. The VRLTA provides guidance for landlords covered by the Act, but no specific time frame. All tenants have options when the response time seems unreasonable or the landlord has refused to respond. First, reread the lease agreement and make sure the responsibility to resolve the issue is the landlord's. If so:

- ▶ **Contact the landlord again.** In some instances, landlords may pay for utilities, such as water, sewer, trash removal and hot water. When the pipe leaks under the sink, you don't head to your nearest hardware store; instead, you head for the phone and call your landlord.
- ▶ **Reach out to area resources for guidance or direct assistance.** The local Health Department may be particularly interested in health and safety concerns. Issues that violate the terms of the lease agreement, or the tenant's rights, would be a concern for Legal Aid offices. Local code and compliance offices may intervene as well.

## Never refuse to pay your rent!

You have the legal right to have the matter heard in court and, in some circumstances, pay your rent to the court. This process is known as Tenant Assertion or Rent Escrow. It's important to be current on your rent and to stay current to begin this process. The clerk of the court may provide more information regarding this course of action, including:

- ▶ Applicable conditions (primarily health and safety issues).
- ▶ Prior written notice to the landlord.
- ▶ Reasonable time (generally 30 days except in emergency situations; unreasonable delays are left to the discretion of the court).
- ▶ Landlord-caused, not tenant-caused, matters.
- ▶ Paying rent.
- ▶ Hearing timeline.
- ▶ Retaliation law.



## Menu

- 1 Are You Financially Ready to Rent?
- 2 The Ins & Outs of Credit
- 3 How to Find the Right Place
- 4 Handling the Application Process
- 5 Understanding the Lease Agreement
- 6 Getting Back Your Security Deposit
- 7 Life as a Renter: Rights & Responsibilities
- 8 Housekeeping, Maintenance & Repairs
- 9 The Right Way to Terminate the Lease

You are urged to contact your local Fair Housing Office or the Department of Professional and Occupational Regulation (DPOR) directly regarding issues that may also involve discrimination. If you believe, or have proof, that the landlord's unreasonable response time or refusal to respond is a matter of discrimination, report it. The law prohibits housing violations based on race, color, national origin, sex, disability, familial status or elderliness.

## Emergencies

Only in cases of emergencies may the landlord, their agent, maintenance staff or contractors enter your dwelling without prior notice. An emergency situation is one that threatens the health and safety of occupants, the property, the neighbors and their properties. Some emergencies are obvious, while others are presumed. Obvious emergencies are signs of smoke and flames coming from a dwelling, or water seeping from under a unit's door. These are clear signs that something or someone has ignited a fire or that water from a fixture or piping has caused major flooding. Not-so-apparent emergency threats often become a judgment call for the landlord. Should the landlord enter when the tenant is not at home when a possible danger exists? Let's look at a few scenarios.

- ▶ **Scenario 1.** A family can hear the smoke detector alarm going off in the apartment next door. Knowing the occupant works the night shift and is most likely not at home, they decide to call the emergency number provided to all tenants. The superintendent calls the contact number for the tenant but gets no response. Minutes later he arrives at the unit to hear the alarm. Although there is no sign of smoke or fire, he decides to enter the unit.
- ▶ **Scenario 2.** A tenant calls the rental office to report that his bathroom floor is flooded with water. He can't tell where it is coming from. The superintendent responds immediately by turning off the water from the main line. This temporary action affects several units within the apartment complex. A plumber is called in. To assess the problem fully, the plumber will need to enter the apartment below as well. The downstairs unit's tenant is not at home and cannot be reached. The superintendent makes the decision to enter the unit with the plumber.

## Menu

- 1 Are You Financially Ready to Rent?
- 2 The Ins & Outs of Credit
- 3 How to Find the Right Place
- 4 Handling the Application Process
- 5 Understanding the Lease Agreement
- 6 Getting Back Your Security Deposit
- 7 Life as a Renter: Rights & Responsibilities
- 8 Housekeeping, Maintenance & Repairs
- 9 The Right Way to Terminate the Lease



## Scenario Review

In both scenarios, a judgment call was made. A smoke detector alarm would indicate there is smoke and/or a fire within the unit, and flooding of a bathroom could indicate a broken pipe and water damage to the unit below. The smell of gas or any other unusual odor would also be an acceptable cause to enter a tenant's unit without notice. Landlords are also required to allow law enforcement with a warrant into a tenant's dwelling.

## Emergency Preparedness Steps

So far this chapter has discussed several health and safety issues. Here are a few emergency preparedness steps:

- ▶ Always have a list of emergency numbers readily available.
- ▶ Invest in one or more home fire extinguishers.
- ▶ Have a first aid kit (ointments, dry sterile dressing, etc.).
- ▶ Know the location of emergency shut-off valves and switches (electricity, water, gas, etc.).
- ▶ Be familiar with the thermostat on your hot water tank.
- ▶ Buy a few flashlights and extra batteries.

Visit the Red Cross' website at [redcross.org](http://redcross.org) for more information

## Preventive Maintenance

Preventive maintenance could be described as taking action to minimize health and safety risks, limit excessive maintenance issues and ensure the appropriate repair or replacement of your rental unit's operating systems and appliances. Below is a list of preventive maintenance tasks that should be the joint responsibility of both the landlord and the tenant. Those denoted by an \* are usually the sole responsibility of the landlord and should not be performed by the tenant.

- ▶ **Electricity:**
  - Install ground fault circuit interrupters (GFCI).\*
  - Test outlets annually.\*
  - Replace faulty wiring immediately.\*
  - Limit the use of extension cords.
  - Do not repair with tape.
  - Don't mix water and electricity.

## Menu

- 1 Are You Financially Ready to Rent?
- 2 The Ins & Outs of Credit
- 3 How to Find the Right Place
- 4 Handling the Application Process
- 5 Understanding the Lease Agreement
- 6 Getting Back Your Security Deposit
- 7 Life as a Renter: Rights & Responsibilities
- 8 Housekeeping, Maintenance & Repairs
- 9 The Right Way to Terminate the Lease

- Install child protective devices.
- Cover and tighten electrical outlets.

► **Appliances** can get hot, so remember to:

- Keep areas around appliances clean and clutter-free.
- Check regularly for broken parts.
- Inspect power cords for frayed or corroded wires.
- Unplug small items such as toasters and coffeemakers when not in use.

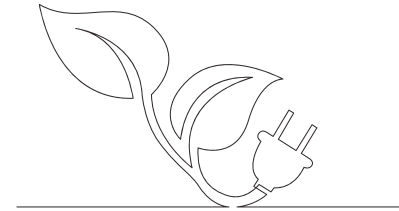

► **Plumbing**

Clogs are a preventable problem. Please do not flush the following down a toilet or pour them down a drain:

- Small toys.
- Disposable diapers.
- Feminine hygiene products.
- Toothpaste or soap.
- Hair.
- Hot wax.
- Grease or cooking oil.
- Food particles.
- Coffee grounds.
- Dirt.

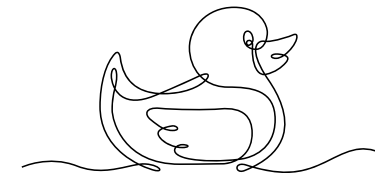

*Especially hazardous and environmental pollutants are:*

- Gasoline.
- Motor oil.
- Antifreeze.
- Pesticides.
- Fertilizers.
- Paint.



# Menu

- 1 Are You Financially Ready to Rent?
- 2 The Ins & Outs of Credit
- 3 How to Find the Right Place
- 4 Handling the Application Process
- 5 Understanding the Lease Agreement
- 6 Getting Back Your Security Deposit
- 7 Life as a Renter: Rights & Responsibilities
- 8 Housekeeping, Maintenance & Repairs
- 9 The Right Way to Terminate the Lease

# Menu

- 1 Are You Financially Ready to Rent?
- 2 The Ins & Outs of Credit
- 3 How to Find the Right Place
- 4 Handling the Application Process
- 5 Understanding the Lease Agreement
- 6 Getting Back Your Security Deposit
- 7 Life as a Renter: Rights & Responsibilities
- 8 Housekeeping, Maintenance & Repairs
- 9 The Right Way to Terminate the Lease

## ► Heating, ventilation and air conditioning:

- Inspect filter routinely for cleaning or replacement.
- Clean dirt, leaves and debris from outdoor units (single-family homes).

## ► General Tips:

- Practice kitchen safety — never leave anything cooking unattended.
- Never place power cords under carpets.
- Never leave plugged-in items unattended, such as irons and space heaters.
- Never leave lit items, such as candles or cigarettes, unattended.
- Always grill in open, well ventilated areas.
- Shut off space heaters before going to bed. Read instructions carefully and place heaters a safe distance from curtains, beds and other furniture. Note: Some landlords prohibit the use of space heaters.

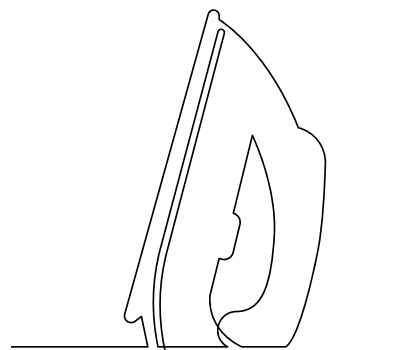

## Property

The overriding rule is to care for the property as if it were your own. Destroying or damaging the landlord's property is a violation of the lease. If the destruction is deliberate, it becomes criminal — a violation of the law.

Other maintenance and preventive issues include pest exterminations, bedbugs, mold and renters insurance.

## Pest Exterminations

Keeping insects and rodents away from your home is important, since they carry germs and diseases that can affect your health. Common household pests such as ants, roaches and mice are attracted to trash and other types of garbage. Keeping your home clean and free of garbage can often deter them. Unfortunately, even the cleanest of apartments can become infested. Tenants should notify the landlord immediately if any pest infestation occurs (an occasional bug is not considered an infestation). Notification is mandatory.

However, many landlords will perform routine extermination of the entire complex to deter or minimize common types of infestation. Landlords must give a tenant no less than 48 hours' prior notice before applying any insecticide or pesticide in the tenant's unit. Chemical treatment can begin with less than 48 hours' notice if the tenant has requested the application and has agreed to the earlier time. In addition, landlords must place signs notifying tenants of the application throughout the premises where the insecticide or pesticide will be applied, and must do so 48 hours before treatment. It is your responsibility to have your rental unit ready. Preapplication instructions are generally provided by the landlord or the extermination company. Notify the landlord in writing within 24 hours if you have a concern about the chemicals.

## Bedbugs

Bedbugs are insects that feed on human blood. They live and breed in areas where many people sleep, such as hotels, apartment complexes and homeless shelters. In some cases, bedbugs have infested entire apartment buildings. If you feel you have a problem with bedbugs, notify your landlord immediately.

Warning: Tenants could be responsible for the cost of treatment if the infestation is not reported promptly or there was a failure to prevent it. The sooner the application used to eliminate bedbugs takes place, the better the chances are there won't be an infestation. Typically, if one unit has bedbugs, the units around the infested unit will also be treated. To avoid attracting bedbugs:

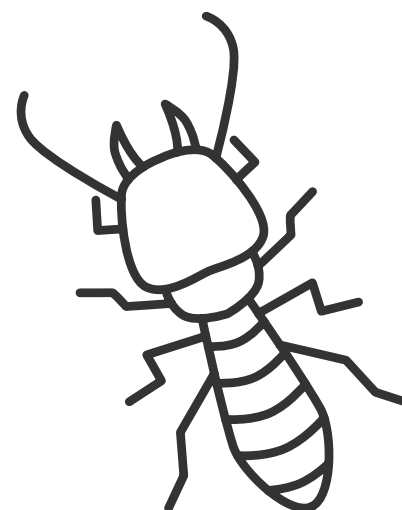

## Menu

- 1 Are You Financially Ready to Rent?
- 2 The Ins & Outs of Credit
- 3 How to Find the Right Place
- 4 Handling the Application Process
- 5 Understanding the Lease Agreement
- 6 Getting Back Your Security Deposit
- 7 Life as a Renter: Rights & Responsibilities
- 8 Housekeeping, Maintenance & Repairs
- 9 The Right Way to Terminate the Lease

- ▶ Vacuum mattress and box springs regularly.
- ▶ Wash bedding frequently.
- ▶ Do not bring mattresses into your home that were placed outside for a long period of time.
- ▶ Avoid used mattresses and fabric-covered furniture.
- ▶ When staying in a hotel, never put your luggage on the bed — place it on a luggage rack or in the bathroom.
- ▶ If you see bedbugs in a hotel room, immediately ask to change rooms.
- ▶ Vacuum luggage after returning from a trip (especially hotel stays) and immediately wash your clothes with hot water.

## Mold

Left untreated, mold has the potential to cause health problems. The U.S. Environmental Protection Agency (EPA) has prepared a useful guide for homeowners and renters entitled *Mold, Moisture, and Your Home*.

Landlords must either disclose to the tenant visible mold or provide a report indicating the unit is free of mold. If the tenant discovers mold after moving in, they have five days from the move-in inspection to provide the landlord with written notice that mold does exist. The tenant can then either terminate the lease or remain in the property. If they chose to stay, the landlord must remove the mold within five business days. Afterward, the property must be reinspected to confirm the property is free of mold.

Unless the mold problem was caused by the tenant, the landlord is responsible for all costs. If it is necessary for the tenant to vacate the dwelling during mold removal, the landlord is responsible for relocating the tenant and the relocation costs.

## Menu

- 1 Are You Financially Ready to Rent?
- 2 The Ins & Outs of Credit
- 3 How to Find the Right Place
- 4 Handling the Application Process
- 5 Understanding the Lease Agreement
- 6 Getting Back Your Security Deposit
- 7 Life as a Renter: Rights & Responsibilities
- 8 Housekeeping, Maintenance & Repairs
- 9 The Right Way to Terminate the Lease



# Renters Insurance

Because there are unforeseen hazards everywhere, things can happen that could result in property damages and/or injury to occupants. Hazards that can result in expensive repairs or high medical bills include:

- ▶ Fire and smoke.
- ▶ Ice, snow and sleet.
- ▶ Theft and vandalism.
- ▶ Flooding.
- ▶ Wind and hail storms.
- ▶ Damage caused by vehicles.

A landlord's insurance policy provides financial protection for the rental property against losses due to hazards. However, if your personal property is destroyed by water damage, fire or other hazards, the landlord's policy will not cover this. That's why tenants are encouraged to purchase a renters insurance policy. A standard renters insurance policy provides content and liability coverage that protects your furniture, clothing, electronics and household items from being a total loss. In addition, renters insurance covers expenses that occur from bodily injuries (liability). Although policies vary, most renters insurance is very affordable. It's recommended that you shop around to find the amount of coverage, premium and deductible that best fits your needs.

Some lease agreements require tenants to have renters insurance as a provision of the lease. When this is the case, the tenant agrees to provide the landlord sufficient proof that a policy was purchased.



**Test Your Knowledge.** Take the quiz for this chapter and get a certificate of completion! You'll be asked to create a user login, if you haven't already: <https://VirginiaHousinglearningcenter.mkscloud.com>

## Menu

- 1 Are You Financially Ready to Rent?
- 2 The Ins & Outs of Credit
- 3 How to Find the Right Place
- 4 Handling the Application Process
- 5 Understanding the Lease Agreement
- 6 Getting Back Your Security Deposit
- 7 Life as a Renter: Rights & Responsibilities
- 8 Housekeeping, Maintenance & Repairs
- 9 The Right Way to Terminate the Lease

# Chapter 9

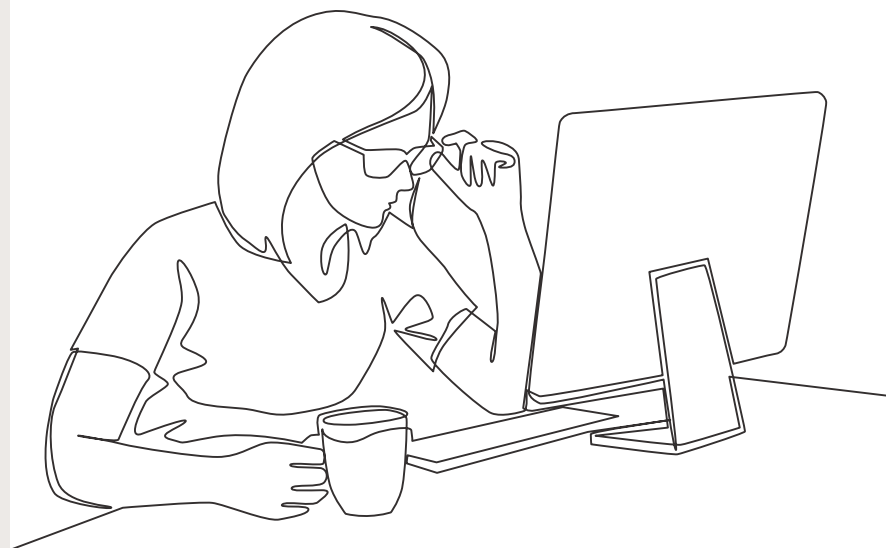

## The Right Way to Terminate the Lease

Terminating a lease agreement isn't as simple as you might think. Both the landlord and you, the tenant, must follow certain procedures to properly end the tenancy.

No matter what type of lease, it's important to understand that it is your responsibility to provide sufficient notice to the landlord prior to vacating

the unit. In addition, as a tenant, you have the right to receive proper notice when the landlord intends to terminate your lease agreement. This chapter examines both sides, provides a legal summary of how court procedures work and reviews various legal documents in Virginia. It also outlines the possible costs you could face after terminating your lease.

## Menu

- 1 Are You Financially Ready to Rent?
- 2 The Ins & Outs of Credit
- 3 How to Find the Right Place
- 4 Handling the Application Process
- 5 Understanding the Lease Agreement
- 6 Getting Back Your Security Deposit
- 7 Life as a Renter: Rights & Responsibilities
- 8 Housekeeping, Maintenance & Repairs
- 9 The Right Way to Terminate the Lease

## Provide the Landlord with Notice

Providing your landlord with notice as outlined in your lease agreement is essential. First and foremost, refer back to the “terminating lease” section of your agreement. Reread the lease agreement. **Never abandon the property.** In other words, don’t just move out (vacate) without letting the landlord know. This is often a costly mistake. Not only will you forfeit your security deposit, but you’ll also be liable for any damages due to vandalism, theft and any other financial loss to the landlord.

Surrender the premises in good condition. Reasonable wear and tear is expected. To make sure you receive any security deposit refund, don’t forget to provide a forwarding address. If you aren’t sure about the lease termination process, don’t hesitate to contact the landlord for clarification and instructions. Seek assistance from a professional, such as a HUD Housing Counseling Agency.

## Tenant’s Intent to Vacate: Provide Sufficient Notice

As a rental tenant, you may terminate the lease agreement without reason once the lease term is up. Even so, most lease agreements often require the tenant to provide written notice in advance of the intended move-out date. Make sure you know how much notice is required — usually 30 or 60 days. Deliver the notice by hand or by mail, as indicated in the lease agreement. Include the following information and don’t forget to keep a copy for your records.

- ▶ Your name
- ▶ Unit address
- ▶ Date of the notice
- ▶ Intended vacate date



## Menu

- 1 Are You Financially Ready to Rent?
- 2 The Ins & Outs of Credit
- 3 How to Find the Right Place
- 4 Handling the Application Process
- 5 Understanding the Lease Agreement
- 6 Getting Back Your Security Deposit
- 7 Life as a Renter: Rights & Responsibilities
- 8 Housekeeping, Maintenance & Repairs
- 9 The Right Way to Terminate the Lease

# Tenant Termination: Before the Lease Expires

If you move out before the lease term expires, there may be penalties. An early termination fee and forfeiture of the security deposit are two of the most common penalties. In some cases, tenants can be held responsible for rent until the lease term expires or the unit is rerented, whichever comes first.

## Early Termination Scenario

Here's one possible scenario: A tenant signed a one-year lease, starting May 1 and terminating April 30 of the following year. The tenant vacated early, on January 31. The tenant can now be held legally responsible for February, March and April rent. However, if the landlord rerents the unit on March 1, the tenant is only responsible for February's rent; the landlord cannot collect rent from both the vacating and new tenants for the months of March and April.

There are some exceptions for early lease termination that may eliminate some or all penalties:

### ► Military Relocation

Special provisions are given to members of the military who receive certain relocation orders. This includes members of the U. S. armed forces and the Virginia National Guard on full-time duty, or those working as Civil Service technicians. The servicemember can terminate the lease early if a permanent change of station order or a temporary duty order for three months or more is received. In addition, the service member is still required to give written notice of not less than 30 days from the first date of the next rental payment. The termination date cannot be more than 60 days from when the servicemember has to depart. This prevents

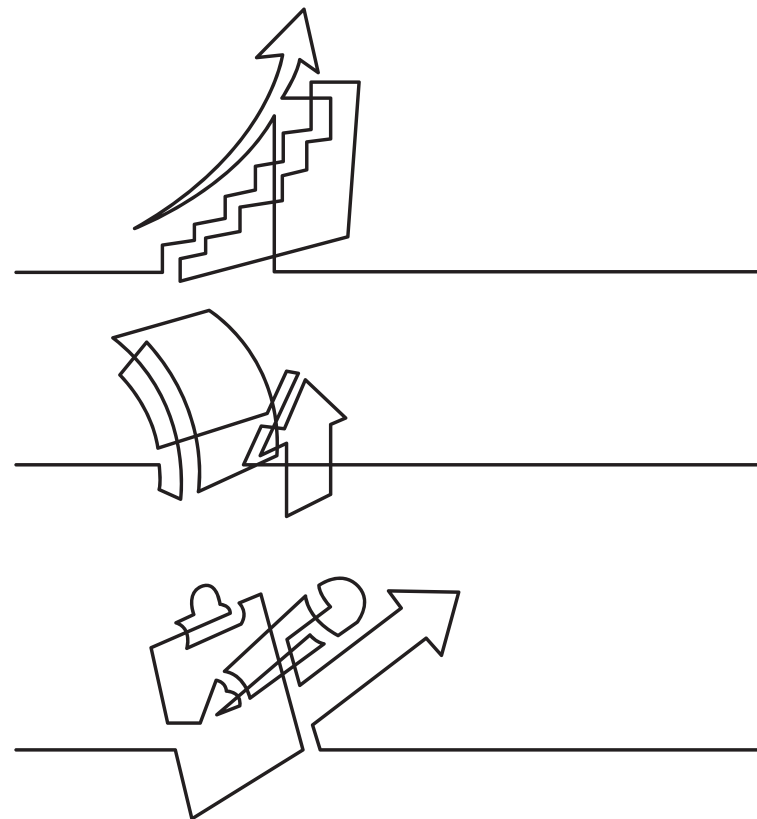

## Menu

- 1 Are You Financially Ready to Rent?
- 2 The Ins & Outs of Credit
- 3 How to Find the Right Place
- 4 Handling the Application Process
- 5 Understanding the Lease Agreement
- 6 Getting Back Your Security Deposit
- 7 Life as a Renter: Rights & Responsibilities
- 8 Housekeeping, Maintenance & Repairs
- 9 The Right Way to Terminate the Lease

servicemembers from terminating and vacating dwellings earlier than they have to. Eligible servicemembers must present a copy of the relocation order to the landlord. The Servicemembers Civil Relief Act (SCRA) can provide more specifics.

▶ **Victims of Abuse or Assault**

Special provisions exist for victims of family abuse, sexual abuse and criminal sexual assaults. The victim must obtain an order of protection, but the tenant does not have to show that the abuser was convicted of a crime. However, in some cases the tenant doesn't need a protective order at all, but can show that the abuser was convicted of certain crimes. The tenant must provide written notice to terminate, and provide a copy of the protection or conviction order. Any co-tenant, however, remains responsible for rent until the end of the agreement term.

▶ **Good Cause**

Some more lenient landlords may release tenants with "good cause" from their lease agreement with minimum or no penalty. Good cause may include tenants who experience job loss through no fault of their own, out-of-area job relocation, unexpected medical issues or other unforeseen events. If any of these events impact you, you're encouraged to speak with your landlord.

▶ **Changes in Family**

Changes in the size of one's family may also merit landlord leniency. Increases in family size due to marriage, children or taking in an elderly parent are examples of family changes. Always be sure to get the approval in writing when the landlord agrees to release you early from your lease agreement.

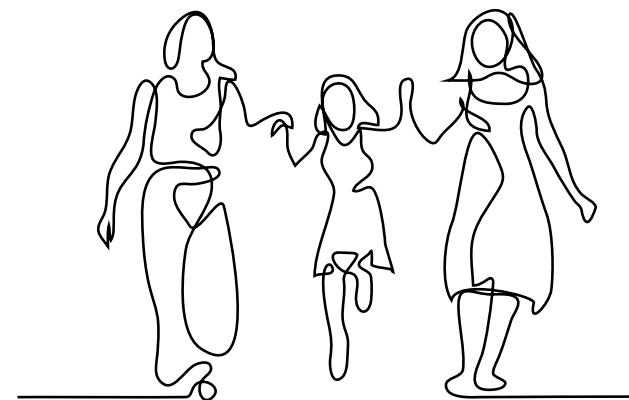

# Menu

- 1 Are You Financially Ready to Rent?
- 2 The Ins & Outs of Credit
- 3 How to Find the Right Place
- 4 Handling the Application Process
- 5 Understanding the Lease Agreement
- 6 Getting Back Your Security Deposit
- 7 Life as a Renter: Rights & Responsibilities
- 8 Housekeeping, Maintenance & Repairs
- 9 The Right Way to Terminate the Lease



# Tenant Termination: Landlord Noncompliance

When a tenant believes the landlord is in noncompliance with the lease agreement and wants to terminate their lease for that reason, they must notify the landlord and specify in writing what the breach is. The notice should include the intended termination date — not less than 30 days — and provide the landlord 21 days to remedy the situation, if possible. If it's not possible to remedy the breach, the notice only needs to state the agreement will terminate in 30 days. The lease will not terminate if the breach is remedied. If the landlord makes the repairs that threaten the health and safety of the tenant within the 21-day period, then the tenant cannot vacate based on landlord noncompliance.

## 30-day Notice

If the breach is remedied and the landlord intentionally commits a similar breach, the tenant only needs to provide a 30-day notice. A 21-day remedy period is not necessary. If the tenant files an assertion, the case will then be heard in court. It is recommended that tenants seek professional advice when they wish to terminate their lease agreement early because of dissatisfaction with the landlord or some provision of the lease agreement. Reasonable attorney's fees may be awarded. Based on the court's ruling, the security deposit may be returned (less damages and unpaid rent) if the court finds the landlord to be in noncompliance with the lease agreement.

## Tenant assertion or rent escrow

When landlord noncompliance is a problem, tenants may want to consider a more serious course of action known as Tenant Assertion or Rent Escrow. This is the process of requesting relief through the courts and paying rent to the courts, which forces the landlord to address serious noncompliance issues. Examples of possible noncompliance issues would be fire safety issues, or any conditions posing a serious threat to the life, health or safety of occupants, such as:

- ▶ Lack of heat, water and/or electricity.
- ▶ Rodent infestation.
- ▶ Sewage disposal.
- ▶ Lead paint.
- ▶ Leaks that allow water to enter the unit.

## Menu

- 1 Are You Financially Ready to Rent?
- 2 The Ins & Outs of Credit
- 3 How to Find the Right Place
- 4 Handling the Application Process
- 5 Understanding the Lease Agreement
- 6 Getting Back Your Security Deposit
- 7 Life as a Renter: Rights & Responsibilities
- 8 Housekeeping, Maintenance & Repairs
- 9 The Right Way to Terminate the Lease

## Prior Written Notice

The tenant must have served prior written notice to the landlord, as well as have provided the landlord reasonable time to remedy the matter, before taking this course of action. The tenant cannot unreasonably refuse the landlord entry to the dwelling to correct the matter. Most importantly, the landlord (not the tenant) must have caused the situation and be responsible for the correction. If the situation is not fixed, or the landlord refuses to correct the problem, the tenant can then ask the courts to review their request for Tenant Assertion.

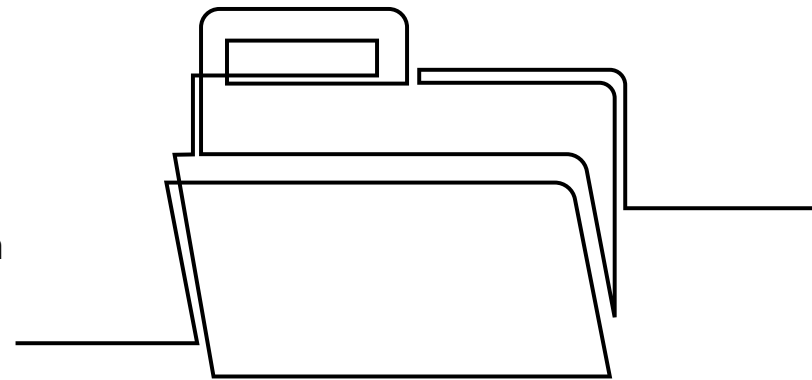

## Filing Tenant Assertion and Complaint Document

Tenants must file the Tenant Assertion and Complaint court document within the jurisdiction where the dwelling is located, and pay all rents due into the court's escrow account within five days of the due date. The initial hearing will be held 15 calendar days after notifying the landlord; emergencies usually receive earlier hearings. The judge will grant applicable relief after hearing both sides and reviewing relevant documents.



*It is illegal for a landlord to retaliate against tenants because they took action against the landlord. Tenants have the legal right to take action in court, and to report code or health violations to authorities. However, it is often very hard to prove retaliation when landlords terminate the agreement at lease expiration.*

# Menu

- 1 Are You Financially Ready to Rent?
- 2 The Ins & Outs of Credit
- 3 How to Find the Right Place
- 4 Handling the Application Process
- 5 Understanding the Lease Agreement
- 6 Getting Back Your Security Deposit
- 7 Life as a Renter: Rights & Responsibilities
- 8 Housekeeping, Maintenance & Repairs
- 9 The Right Way to Terminate the Lease

## Landlord Termination: Lease Expiration

Once the term of the lease is up, the landlord (like the tenant) can terminate the lease agreement without reason. Even so, the landlord must provide notification — typically 30 or 60 days — that the lease will not continue after the expiration date. However, the landlord only needs to provide a 30-day notice for a month-to-month lease agreement and a seven-day notice for weekly agreements. The tenant must remove all personal property, vacate the dwelling and leave it in good, clean condition, less reasonable wear and tear. The landlord may initiate eviction procedures if the tenant fails to vacate on time.

## Landlord Termination: Transfer of Ownership, Property Sale or Foreclosure

**Property sale and transfer of ownership.** Except in the case of a foreclosure, the terms of a lease agreement don't change simply because ownership has transferred or the owner/landlord has sold the property. The new owner is bound by the original/current terms of the lease agreement and cannot make changes during the term without the tenant's permission. The security deposit and other held funds also transfer with the new owners.

**Foreclosed property.** It's important to know that even if you are paying your rent on time, it doesn't mean your landlord is making their mortgage payment on time — or at all. As a result, the property you're renting can be subject to foreclosure. This means that the landlord's mortgageholder (often a bank) can repossess the property. Tenants may have no idea the owner/landlord has lost the property to foreclosure.



## Menu

- 1 Are You Financially Ready to Rent?
- 2 The Ins & Outs of Credit
- 3 How to Find the Right Place
- 4 Handling the Application Process
- 5 Understanding the Lease Agreement
- 6 Getting Back Your Security Deposit
- 7 Life as a Renter: Rights & Responsibilities
- 8 Housekeeping, Maintenance & Repairs
- 9 The Right Way to Terminate the Lease

# Landlord Termination: Noncompliance

A landlord may not ask a tenant to move during the lease period. However, when a tenant fails to comply with the terms of the lease agreement, they are considered to be in noncompliance. In that case, landlords can, and often do, proceed to terminate the lease agreement.

In the case of a foreclosed property, the new owner must honor the existing lease. Tenants with more than 90 days remaining on their lease can remain until the end of the lease period. The only exception is if the new owner will be occupying the unit as a primary residence. In that instance, the new owner must give the tenant a 90-day notice. Tenants with less than 90 days remaining on their lease are still required to receive a 90-day notice. The exception to this would be in the case of a month-to-month lease, in which case termination of the lease will be in accordance with the lease agreement. The tenant must continue making rent payments either to the new owner, the managing agent, or to the court if the new owner or managing agent is unknown.

The Virginia Residential Landlord and Tenant Act and the court system outline the steps landlords must take to terminate a lease due to tenant noncompliance. A tenant should take all notifications and procedures seriously.

## ► **Written Notice of Intent**

A landlord must provide the tenant with written notice of their intent to terminate the tenant's lease agreement. The various required notices include initial notice, immediate termination and court order.

## **The initial notice:**

### ► **5-day Notice – “Pay or Quit”**

Commonly known as a “Pay or Quit,” this notice states that if rent is not paid within five days, the landlord will initiate court proceedings. The notice will include the name of each tenant/lessee and the amount due.

## Menu

- 1 Are You Financially Ready to Rent?
- 2 The Ins & Outs of Credit
- 3 How to Find the Right Place
- 4 Handling the Application Process
- 5 Understanding the Lease Agreement
- 6 Getting Back Your Security Deposit
- 7 Life as a Renter: Rights & Responsibilities
- 8 Housekeeping, Maintenance & Repairs
- 9 The Right Way to Terminate the Lease

# Menu

- 1 Are You Financially Ready to Rent?
- 2 The Ins & Outs of Credit
- 3 How to Find the Right Place
- 4 Handling the Application Process
- 5 Understanding the Lease Agreement
- 6 Getting Back Your Security Deposit
- 7 Life as a Renter: Rights & Responsibilities
- 8 Housekeeping, Maintenance & Repairs
- 9 The Right Way to Terminate the Lease

## ▶ 30-day Notice – “Breach of Lease” (health and safety concerns)

Also referred to as a “21/30 Notice,” this notice states that the tenant has breached one or more provisions of the lease agreement. The tenant has 21 days to remedy the breach. If the tenant fails to remedy the breach, the lease will be terminated at the end of the 30 days. If the same or a similar problem occurs, the landlord does not have to give the tenant another 21-day period to remedy the breach.

January

S	M	T	W	T	F	S
	1	2	3	4	5	6
7	8	9	10	11	12	13
14	15	16	17	18	19	20
21	22	23	24	25	26	27
28	29	30	31			

## ▶ 30-day Notice – “Breach of Lease” (nonremedy)

This notice states that the tenant has breached a lease provision that cannot be remedied. The landlord will terminate the lease agreement at the end of the 30-day period.

## ▶ Immediate “Notice of Termination” (criminal breach)

This notice states that the tenant has breached the lease agreement in a criminal or willful manner that threatens the health and safety of others. Therefore, the landlord can legally terminate the lease agreement immediately.



*Although the landlord has provided notice terminating the lease agreement, the tenant is still entitled to their day in court.*

**The court order – “Unlawful Detainer.”** If a tenant does not pay their rent, or remedy a breach or move out in accordance with the notice given, the landlord will proceed to gain possession of the dwelling and obtain a court order for rent and other monies owed. This will include late fees, court costs and applicable attorney fees. The landlord cannot evict a tenant without going through the court system to obtain judgment for monies owed and/or a writ of possession in order to gain possession. More specifics about both are detailed later in this chapter. Cases are typically held in General District Court, but could also be held in Circuit Court.



# Menu

To recap, the landlord will file an Unlawful Detainer with the clerk of the court. The court will then process a summons requiring the tenant to appear in court. The sheriff's office will serve the summons by regular mail, serve the summons in person or post it on the tenant's door. Tenants should always go to court when summoned. Judgment may be entered against a tenant who is absent from the courtroom, and the landlord may be granted immediate possession of the dwelling. The Unlawful Detainer summons will include a breakdown of monies owed at the time of filing. This includes:

- ▶ Applicable unpaid rent.
- ▶ Interest.
- ▶ Late fee.
- ▶ Damages.
- ▶ Costs.
- ▶ Civil recovery fees.
- ▶ Attorney fees.

In addition, the summons provides important information, including:

- ▶ Plaintiff (owner/landlord) information.
- ▶ Defendant (tenant) information.
- ▶ Dispute information.
- ▶ Hearing date and time.
- ▶ City or county.
- ▶ Court address.
- ▶ Address and description of the rental property.

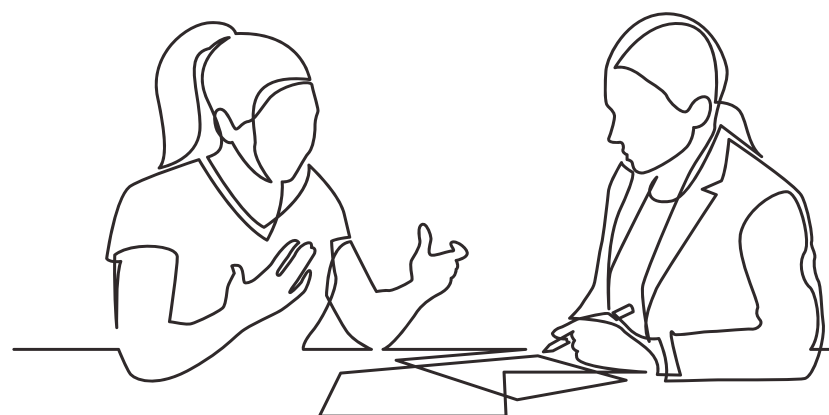

**The hearing.** Both the tenant and the landlord will have the opportunity to present their side of the dispute. If the tenant feels the landlord is proceeding to have them evicted in error, they must be prepared to prove it in court. Sufficient documentation and witnesses (if applicable) are recommended. Judges will rule based on the evidence and testimonies. If the landlord wins in court, the tenant must vacate and will be ordered to pay all monies owed. If the tenant wins, the lease will remain in effect and the tenant can remain in the dwelling. It's important to understand that a court-ordered judgment will appear on your

1 Are You Financially Ready to Rent?

2 The Ins & Outs of Credit

3 How to Find the Right Place

4 Handling the Application Process

5 Understanding the Lease Agreement

6 Getting Back Your Security Deposit

7 Life as a Renter: Rights & Responsibilities

8 Housekeeping, Maintenance & Repairs

9 The Right Way to Terminate the Lease

credit report for at least seven years, and it will lower your credit score. Keep in mind that if the debt remains unpaid after seven years, the landlord can extend the collection time frame with the court for a period of time.



*If the tenant fails to appear in court, the judge can, and often will, enter a judgment in their absence. This is known as a default judgment.*

**Contested case.** Tenants who disagree with the court's decision against them have the opportunity to contest the verdict. The tenant will have to post an appeal bond for the full amount of the judgment within 10 days of the judgment and pay ongoing rent as it becomes due. In addition, the court may order the tenant to prepare a written Grounds of Defense. This order requires you to state in detail why you feel the action brought against you is in error. The court may also order the landlord to prepare a Bill of Particulars that states why the landlord feels the action taken against the tenant is valid. Both documents must be filed with the court by the due date. Failure to file promptly could result in an automatic loss.

**Eviction.** Landlords may enter the dwelling prior to a court order if the tenant has turned in the keys, or if there is overwhelming evidence the property has been abandoned and is causing a potential health and safety issue for others. If neither situation exists, the landlord must wait to receive a court-ordered judgment before entering the dwelling. In addition, the landlord may not disconnect utilities to the dwelling or change the locks.

### Request for Writ of Possession

The court-ordered judgment allows the landlord to proceed with gaining possession of the property. This is known as an eviction. The landlord will file a Request for Writ of Possession in Unlawful Detainer Proceedings document with the court. Information provided in this document includes:

- ▶ Case number.
- ▶ City or county in which the case was heard.
- ▶ Address of the dwelling.
- ▶ Plaintiff's (landlord's) name.
- ▶ Defendant's (tenant's) name.

## Menu

- 1 Are You Financially Ready to Rent?
- 2 The Ins & Outs of Credit
- 3 How to Find the Right Place
- 4 Handling the Application Process
- 5 Understanding the Lease Agreement
- 6 Getting Back Your Security Deposit
- 7 Life as a Renter: Rights & Responsibilities
- 8 Housekeeping, Maintenance & Repairs
- 9 The Right Way to Terminate the Lease

# Menu

- 1 Are You Financially Ready to Rent?
- 2 The Ins & Outs of Credit
- 3 How to Find the Right Place
- 4 Handling the Application Process
- 5 Understanding the Lease Agreement
- 6 Getting Back Your Security Deposit
- 7 Life as a Renter: Rights & Responsibilities
- 8 Housekeeping, Maintenance & Repairs
- 9 The Right Way to Terminate the Lease

The court will transfer the request to the local sheriff’s office. The sheriff will notify the tenant and they must vacate within the time frame contained in the Notice to Vacate. The sheriff will also schedule the eviction date with the landlord and oversee the process on the day of the eviction. The tenant’s belongings will be physically removed from the dwelling and typically placed on a nearby curb. However, if the landlord decides to keep the tenant’s belongings in the home or in storage, the landlord has to give the tenant 24 hours to get their things. Because this can be a very emotional experience, tenants are urged to move out before the deadline contained on the Notice to Vacate. Always provide the landlord with the keys.

## “Accept with Reservation”

It’s important to understand that failure to pay rent and other monies as outlined in the lease agreement is a breach in itself. Often, breach entitles the landlord to terminate the lease and initiate procedures to have you evicted. In other words, the landlord is entitled to both the money owed and possession of the property.

However, the landlord can accept the rent with reservation. If so, the notice must state that payment is accepted with reservation and that the landlord does not waive their right to evict. If the landlord accepts the rent without reservation, with knowledge of the tenant’s noncompliance, then the landlord waives the right to terminate the lease.

The payment received will be applied to delinquent rent and any other monies owed. This does not mean the landlord will evict the tenant, but the landlord does have the right to do so. However, even if the landlord accepts the rent with reservation, the tenant still has a right to redemption, redemption tender, or extended redemption. Tenants are advised to appear in court.

# Right of Redemption

The Right of Redemption, Redemption Tender or Extended Redemption is a legal process that tenants may use to stop eviction for nonpayment of rent. Tenants can exercise this right only once every 12 months. The tenant must pay all amounts owed before (not after) the court date. This includes all:

- ▶ Rent and arrears.
- ▶ Late charges.
- ▶ Interest.
- ▶ Attorney fees.
- ▶ Court costs.

Payment must be by cashier's check, certified check or money order. Get a written receipt after making payment and complete the Notice of Redemption form with the court. You must appear on the date indicated on the Unlawful Detainer. Tenants who have received a promise from a third-party organization or agency to pay on their behalf (after the court date) must file a Redemption Tender with the court. Obtain a written commitment from the organization/agency stating their promise to pay. All amounts owed must be paid within 10 days after the court date. The written promise must state the organization/agency will pay within that time frame.

The final way to pay and stay is two business days before the sheriff's scheduled eviction date. The tenant can pay all monies owed, including sheriff's fees if applicable, and receive an extended Right of Redemption and the sheriff's eviction (Writ of Eviction) is canceled. Payment can be made to the landlord, the landlord's attorney or the court. Be sure to confirm payment receipt with the landlord and the sheriff to be certain.



## Menu

- 1 Are You Financially Ready to Rent?
- 2 The Ins & Outs of Credit
- 3 How to Find the Right Place
- 4 Handling the Application Process
- 5 Understanding the Lease Agreement
- 6 Getting Back Your Security Deposit
- 7 Life as a Renter: Rights & Responsibilities
- 8 Housekeeping, Maintenance & Repairs
- 9 The Right Way to Terminate the Lease

# Warrant in Debt

The name of this court document can be confusing. It is not an arrest warrant, but a civil warrant and is filed by a former landlord when money is owed after the tenant moves out. Unlike the Unlawful Detainer, the Warrant in Debt is for money only, not for possession of the property, because the tenant has already vacated.

## Garnishment

The landlord initiates garnishment procedures to recover monies owed once the judgment is granted. Although the tenant is not required to appear in court, it is highly recommended that they do so. The warrant allows for up to 25% of the former tenant's paycheck and/or up to 100% of the tenant's individual bank account.

### ▶ Example: Garnishment

- **Garnishment Proceeding**

The landlord can file either a Suggestion for Summons in Garnishment or a Writ of Fieri Facias, which is notifying the tenant of garnishment proceeding. The employer and the financial institution are under court order to take the money and submit it to the court, where the landlord will come to retrieve the funds.

- **Garnishment Submitted**

A garnishment submitted to the bank in the amount of \$500 would exhaust the tenant's account if the balance is \$500 or less. If the balance is more than \$500, the bank would only withdraw the garnishment amount.

## Menu

- 1 Are You Financially Ready to Rent?
- 2 The Ins & Outs of Credit
- 3 How to Find the Right Place
- 4 Handling the Application Process
- 5 Understanding the Lease Agreement
- 6 Getting Back Your Security Deposit
- 7 Life as a Renter: Rights & Responsibilities
- 8 Housekeeping, Maintenance & Repairs
- 9 The Right Way to Terminate the Lease



# Menu

- 1 Are You Financially Ready to Rent?
- 2 The Ins & Outs of Credit
- 3 How to Find the Right Place
- 4 Handling the Application Process
- 5 Understanding the Lease Agreement
- 6 Getting Back Your Security Deposit
- 7 Life as a Renter: Rights & Responsibilities
- 8 Housekeeping, Maintenance & Repairs
- 9 The Right Way to Terminate the Lease

## What Can Be Garnished

An individual's bank account can be garnished for the entire amount of the warrant, or 100% of the account balance if less than the amount due. An account cannot be garnished if the individual's bank account is exempt, such as an account holding primarily Social Security benefits.

## Prevention

Look at all possible options to avoid this type of financial hardship, which include making payment arrangements with the landlord, speaking with a Department of Housing and Urban Development (HUD) certified housing/credit counselor or seeking legal advice.

## Time Line at a Glance

- ▶ Rent is due on the first of the month — this starts the first chance in the Redemption Period.
- ▶ Rent is late on the fifth of the month — check your lease agreement; it may differ.
- ▶ Pay or Quit Notice may be issued after the second of the month — this starts the second chance in the Redemption Period.
- ▶ Unlawful Detainer summons may be issued.
- ▶ Court date. — this starts the third chance in the Redemption Period.
- ▶ Writ of Possession is filed.
- ▶ Notice of Eviction is served with 72-hour notice — this starts the fourth and final chance in the Extended Redemption Period.
- ▶ Eviction.



**Test Your Knowledge.** Take the quiz for this chapter and get a certificate of completion! You'll be asked to create a user login, if you haven't already: <https://VirginiaHousinglearningcenter.mkscloud.com>

# Resources for Renters

## Fair Housing Consultation

### Department of Professional and Occupational Regulation (DPOR)

If you're in a dispute with a landlord, DPOR can assist in many ways. They have the Alternative Dispute Resolution (ADR), a free confidential process in which an impartial third party assists tenants and landlords in reaching a settlement. The impartial third party, who volunteers their services to DPOR, is certified as a mediator by the Virginia Supreme Court. DPOR employees who are trained or have experience with dispute resolution are also used in this process.

804-367-8530

[dpor.virginia.gov/FairHousing/](http://dpor.virginia.gov/FairHousing/)

### Department of Housing and Urban Development (HUD)

If you're trying to rent or buy a property and feel you've been discriminated against because of your race, color, national origin, religion, sex, family status or disability, you can file a complaint with HUD at no cost. HUD will review your complaint. If it is determined your complaint isn't in their jurisdiction, HUD will consider the case closed. If the complaint is in their jurisdiction, HUD will investigate. Should the investigation's outcome determine that a violation of the Fair Housing Act has occurred, HUD will help you complete an official housing discrimination complaint. All parties will be contacted. The possible outcomes are:

- ▶ **Conciliation.** Parties involved in the complaint sign a conciliation agreement, and then HUD closes the case. However, if one party violates the agreement, HUD can recommend that the U.S. Department of Justice file suit to enforce the agreement.
- ▶ **No Cause Determination.** HUD determines that a violation has not occurred or is not going to occur and closes the case.

## Menu

- 1 Are You Financially Ready to Rent?
- 2 The Ins & Outs of Credit
- 3 How to Find the Right Place
- 4 Handling the Application Process
- 5 Understanding the Lease Agreement
- 6 Getting Back Your Security Deposit
- 7 Life as a Renter: Rights & Responsibilities
- 8 Housekeeping, Maintenance & Repairs
- 9 The Right Way to Terminate the Lease

- ▶ **Cause Determination and Charge.** The respondent is charged with violating the law, based on HUD’s investigation.
- ▶ **Hearing in U.S. District Court.** Either party can elect to have the case heard in the U.S. District Court.
- ▶ **Hearing Before a HUD Administrative Law Judge.** This happens if neither party elects to have the case heard by the U.S. District Court

You can call HUD for more detailed information on Housing Discrimination at 800-669-9777 or visit [HUD.gov](http://HUD.gov).

## Federal Acts and Legislation

### Americans with Disabilities Act (ADA) Mediation Program

The Americans with Disabilities Act (ADA) Mediation Program, administered by the U.S. Department of Justice, is free for all parties involved. The program informally resolves ADA complaints by allowing those involved to develop solutions that are agreed to by all parties, and which comply with the ADA. The program uses ADA-trained mediators throughout the U.S. The goal of the program is to provide a confidential, voluntary way to resolve ADA complaints fairly and quickly.

### Fair Housing Act

Adopted in 1968 and amended in 1988, this Act prohibits discrimination by landlords, real estate companies and other direct providers of housing. It also prohibits discrimination by municipalities, banks or other lending institutions and homeowners insurance companies whose business practices make housing unavailable based on:

- ▶ Race or color
- ▶ Religion
- ▶ Sex
- ▶ National origin
- ▶ Familial status
- ▶ Disability

## Menu

- 1 Are You Financially Ready to Rent?
- 2 The Ins & Outs of Credit
- 3 How to Find the Right Place
- 4 Handling the Application Process
- 5 Understanding the Lease Agreement
- 6 Getting Back Your Security Deposit
- 7 Life as a Renter: Rights & Responsibilities
- 8 Housekeeping, Maintenance & Repairs
- 9 The Right Way to Terminate the Lease

# Menu

- 1 Are You Financially Ready to Rent?
- 2 The Ins & Outs of Credit
- 3 How to Find the Right Place
- 4 Handling the Application Process
- 5 Understanding the Lease Agreement
- 6 Getting Back Your Security Deposit
- 7 Life as a Renter: Rights & Responsibilities
- 8 Housekeeping, Maintenance & Repairs
- 9 The Right Way to Terminate the Lease

## Servicemembers Civil Relief Act (SCRA)

This federal law, rewritten in 2003, provides protections for military members as they enter active duty. One of the benefits of the Act is that it allows individuals to break a lease when they go on active duty if the lease was entered into prior to active duty. The Act also allows a servicemember to terminate a residential lease entered into while in the military, if the member receives permanent change of station (PCS) orders, or orders to deploy for a period of not less than 90 days.

## Protecting Tenants at Foreclosure Act (PTFA)

This Act provides renters with housing stability when their homes are foreclosed on. Before this federal law was put into place, it was legal in many states for tenants to be required to move with only a few days' notice. Under the PTFA, most tenants now have the right to remain in their home for the remainder of their lease, or for at least 90 days.

## Counseling

### Department of Housing and Urban Development

If you've been unsuccessful in renting a home because of your prior credit or renting issues, a counseling agency may be able to help. Many counseling agencies throughout Virginia can assist you in getting ready to rent. The counselor can review your credit and help you create a plan to begin the removal of delinquent accounts to improve your credit score. The counselor can help you create a Spending and Savings Plan. This Plan can become a live document that you revisit frequently. Contact your local HUD counselor from [HUD.gov](http://HUD.gov) for assistance or updates.

[hud.gov](http://hud.gov)

### Military Financial Educators

In addition to HUD, military personnel can contact any of the following resources for counseling assistance:

- ▶ Air Force Airman and Family Readiness Center (AFRC)
- ▶ Army Army Community Services (ACS)
- ▶ Navy Fleet and Family Support Center (FFSC)
- ▶ Marines Marine Corps Relief Society (MCRS)

# Menu

- 1 Are You Financially Ready to Rent?
- 2 The Ins & Outs of Credit
- 3 How to Find the Right Place
- 4 Handling the Application Process
- 5 Understanding the Lease Agreement
- 6 Getting Back Your Security Deposit
- 7 Life as a Renter: Rights & Responsibilities
- 8 Housekeeping, Maintenance & Repairs
- 9 The Right Way to Terminate the Lease

## Legal

If you keep getting denied rental opportunities because of something in your history that keeps coming up, you can contact several agencies for assistance. These agencies have offices in many parts of Virginia, and you should call the one the closest to you. Below is a list of national numbers that can help you locate your local office.

- ▶ Legal Aid Society of Virginia [vlas.org](http://vlas.org) 866-534-5243
- ▶ Legal Services of Northern Virginia [lsnv.org](http://lsnv.org) 703-778-6800
- ▶ Central Virginia Legal Aid Society [vlas.org](http://vlas.org) 800-868-1012 Richmond/  
Petersburg 800-390-9982 Charlottesville
- ▶ Southwest Virginia Legal Aid Society [svlas.org](http://svlas.org) 866-534-5243
- ▶ Legal Aid Justice Center [justice4all.org](http://justice4all.org) 804-643-1086 Richmond  
434-977-0553 Charlottesville  
703-778-3450 Northern VA  
804-862-2205 Petersburg

Additional assistance can be received by military personnel by contacting the office of the Judge Advocate General (JAG) for their military branch.

## Virginia Courts

To see a detailed breakdown of the Virginia court system, visit [courts.state.va.us/courts/home.html](http://courts.state.va.us/courts/home.html).



# Financial Assistance

## Department of Housing and Community Development (DHCD)

This state agency has a variety of programs that might be able to assist you. A few of DHCD's program are listed here. You can also contact DHCD directly to find out about additional programs.

- ▶ **Affordable and Special Needs Housing (ASNH)** fills gaps in financing the development of new and rehabilitated affordable and special needs housing for low-income Virginians.
- ▶ **The Virginia Homeless Solutions Program (VHSP)** is funded by the State General Fund and the federal Emergency Solutions Grant (ESG) to support Continuum of Care (CoC) strategies and homeless service and prevention programs that align with the following goals to:
  - Reduce the number of individuals/households who become homeless;
  - Shorten the length of time an individual or household is homeless; and
  - Reduce the number of individuals/households that return to homelessness.
- ▶ **Virginia Individual Development Accounts (VIDA)** is a program to help individuals saving for a down payment on a home, business equipment and inventory, or post-secondary education tuition payments. Eligible participants receive training, support and \$8 in matching funds for every \$1 the participant saves, up to \$4,000 in match.

To learn more about programs available through DHCD, please call 804-371-7000 or visit their website at [dhcd.virginia.gov](http://dhcd.virginia.gov).

### Power Pay

This free tool, created by Utah State University, can help you to review your financial situation and create a goal to eliminate your debt. It can also help you in develop a

Spending and Savings Plan. [powerpay.org](http://powerpay.org)

## Menu

- 1 Are You Financially Ready to Rent?
- 2 The Ins & Outs of Credit
- 3 How to Find the Right Place
- 4 Handling the Application Process
- 5 Understanding the Lease Agreement
- 6 Getting Back Your Security Deposit
- 7 Life as a Renter: Rights & Responsibilities
- 8 Housekeeping, Maintenance & Repairs
- 9 The Right Way to Terminate the Lease

# Rental Search

## VirginiaHousingSearch.com

This housing locator service was launched across Virginia in June 2009. Sponsored by the Virginia Housing (Virginia Housing), VirginiaHousingSearch.com provides detailed information about rental properties and can help prospective renters find housing that best fits their needs.

The free service is available online 24 hours a day or through a toll-free, bilingual call center at 877-428-8844, Monday – Friday, 9 a.m. – 8 p.m. EST.

[virginiahousingsearch.com](http://virginiahousingsearch.com)

## Housing Choice Voucher Program (formerly called Section 8)

Housing Choice Vouchers are administered by local housing authorities. The housing authorities receive federal funds from the Department of Housing and Urban Development (HUD) to administer the voucher program, also known as Section 8. Resources to contact for additional information on the voucher program in your area include:

- ▶ [HUD.gov](http://HUD.gov) 800-955-2232
- ▶ [VirginiaHousing.com](http://VirginiaHousing.com) 877-843-2123
- ▶ [GoSection8.com](http://GoSection8.com)

## ACCESS VA

This website enables Virginians with disabilities to find an affordable, accessible place to live. Accessva.org also provides a variety of other information, including accessible housing resources and an interactive map of Virginia Centers for Independent Living (CILs).

[accessva.org](http://accessva.org)

# Menu

- 1 Are You Financially Ready to Rent?
- 2 The Ins & Outs of Credit
- 3 How to Find the Right Place
- 4 Handling the Application Process
- 5 Understanding the Lease Agreement
- 6 Getting Back Your Security Deposit
- 7 Life as a Renter: Rights & Responsibilities
- 8 Housekeeping, Maintenance & Repairs
- 9 The Right Way to Terminate the Lease

## The American Red Cross

Some of the services the American Red Cross provides are for people who have been displaced due to a disaster. The organization also helps military families cope with the various challenges they may face. Visit the American Red Cross website for more information or to contact your local office.

[redcross.org](http://redcross.org)

## Reducing Solicitations

These resources can help reduce mail or phone call solicitations:

- ▶ Pre-screened mailing lists  
888-5OPT-OUT (888-567-8688)  
[optoutprescreen.com](http://optoutprescreen.com)
- ▶ Telemarketing calls  
888-382-1222  
[donotcall.gov](http://donotcall.gov)
- ▶ Direct mailing services  
[dmachoice.org](http://dmachoice.org)

## Credit Reports

### Credit Reporting Agencies

Here are the top three credit reporting agencies and their contact information:

- ▶ Equifax Information Services, LLC  
P.O. Box 740256, Atlanta, GA 30374  
Phone: Number listed at the top of your credit report.  
[equifax.com/online-credit-dispute](http://equifax.com/online-credit-dispute)

## Menu

- 1 Are You Financially Ready to Rent?
- 2 The Ins & Outs of Credit
- 3 How to Find the Right Place
- 4 Handling the Application Process
- 5 Understanding the Lease Agreement
- 6 Getting Back Your Security Deposit
- 7 Life as a Renter: Rights & Responsibilities
- 8 Housekeeping, Maintenance & Repairs
- 9 The Right Way to Terminate the Lease

- ▶ Experian  
Mail: Address listed at top your credit report.  
Phone: Toll-free number listed at the top of your credit report.  
[experian.com/disputes2](http://experian.com/disputes2)
- ▶ TransUnion Consumer Solutions  
Mail: P.O. Box 2000, Chester, PA 19022-2000  
Phone: 800-916-8800  
[annualcreditreport.transunion.com/entry/disputeonline](http://annualcreditreport.transunion.com/entry/disputeonline)

Other sources to view your credit report include:

- ▶ [AnnualCreditReport.com](http://AnnualCreditReport.com)
- ▶ [myfico.com](http://myfico.com)
- ▶ [vantagescore.com](http://vantagescore.com)

## Identity Theft Assistance

Along with the counselors and credit agencies previously referenced, the Federal Bureau of Investigation (FBI) can assist you in avoiding identity theft or resolving an identity theft issue.

[fbi.gov](http://fbi.gov)

## Publications

### Virginia Residential Landlord and Tenant Act / Virginia Fair Housing Law Overview

The Virginia Residential Landlord and Tenant Act (VRLTA) handbook spells out the rights, remedies and responsibilities of landlords and renters concerning the rental process.

<https://www.dhcd.virginia.gov/>

## Menu

- 1 Are You Financially Ready to Rent?
- 2 The Ins & Outs of Credit
- 3 How to Find the Right Place
- 4 Handling the Application Process
- 5 Understanding the Lease Agreement
- 6 Getting Back Your Security Deposit
- 7 Life as a Renter: Rights & Responsibilities
- 8 Housekeeping, Maintenance & Repairs
- 9 The Right Way to Terminate the Lease

## Modification - Fair Housing Act

A publication with information on modifications covered by the Fair Housing Act, along with questions and answers about the Act, can be found at:

[Department of Justice – Reasonable Modification under the Fair Housing Act](#)

## Fair Housing and People with Disabilities

As does federal law, the Virginia Fair Housing Law prohibits housing discrimination — in public and private housing — based on race, color, religion, national origin, sex, elderliness, familial status and handicap (disability). Learn more about the law here:

▶ English -

[http://www.dpor.virginia.gov/uploadedFiles/MainSite/Content/FairHousing/VFHO%20Disability%20Brochure\\_rev12-2013.pdf](http://www.dpor.virginia.gov/uploadedFiles/MainSite/Content/FairHousing/VFHO%20Disability%20Brochure_rev12-2013.pdf)

▶ Spanish -

[http://www.dpor.virginia.gov/uploadedFiles/MainSite/Content/FairHousing/VFHO%20Disability%20Brochure%20\(Spanish\)\\_rev12-2013.pdf](http://www.dpor.virginia.gov/uploadedFiles/MainSite/Content/FairHousing/VFHO%20Disability%20Brochure%20(Spanish)_rev12-2013.pdf)

## Hoarding

Hoarding is the excessive accumulation of items and the inability to discard them. Also known by the medical name “disposophobia,” it has gained more public awareness due to shows like Hoarders and Hoarding: Buried Alive. This link gives you more information:

[http://www.dpor.virginia.gov/uploadedFiles/MainSite/Content/FairHousing/VFHO%20hoarding%20brochure\\_general.pdf](http://www.dpor.virginia.gov/uploadedFiles/MainSite/Content/FairHousing/VFHO%20hoarding%20brochure_general.pdf)

# Menu

- 1 Are You Financially Ready to Rent?
- 2 The Ins & Outs of Credit
- 3 How to Find the Right Place
- 4 Handling the Application Process
- 5 Understanding the Lease Agreement
- 6 Getting Back Your Security Deposit
- 7 Life as a Renter: Rights & Responsibilities
- 8 Housekeeping, Maintenance & Repairs
- 9 The Right Way to Terminate the Lease





# ▶ Congratulations

You're on Your Way to Being  
a Successful Renter!

## Menu

- 1 Are You Financially Ready to Rent?
- 2 The Ins & Outs of Credit
- 3 How to Find the Right Place
- 4 Handling the Application Process
- 5 Understanding the Lease Agreement
- 6 Getting Back Your Security Deposit
- 7 Life as a Renter: Rights & Responsibilities
- 8 Housekeeping, Maintenance & Repairs
- 9 The Right Way to Terminate the Lease